

**STAMFORD UNIVERSITY BANGLADESH**  
**DEPARTMENT OF CIVIL ENGINEERING**

---



**STRUCTURAL MODELING OF A  
RESIDENTIAL BUILDING**

**Abdullah Al-Ferdous**  
ID: CEN 060 09263

**Based Mia**  
ID: CEN 060 09206

**Rashel Mahmud**  
ID: CEN 060 09265

**Md. Sahinur Rahman**  
ID: CEN 060 09280

**SEPTEMBER 2020**

# **STRUCTURAL MODELING OF A RESIDENTIAL BUILDING**

A Project and Thesis

By

**Abdullah Al-Ferdous**

ID: CEN 060 09263

**Based Mia**

ID: CEN 060 09206

**Rashel Mahmud**

ID: CEN 060 09265

**Md. Sahinur Rahman**

ID: CEN 060 09280

Supervised

By

**MD. MAHBUB-UL-ALAM**

Associate Professor

Department of Civil Engineering

In partial fulfillment of the requirement for the Degree of Bachelor of Science (B.Sc.) in  
Civil Engineering.

**SEPTEMBER 2020**



**STAMFORD UNIVERSITY BANGLADESH**  
**DEPARTMENT OF CIVIL ENGINEERING**

---

The project and thesis titled “**Structural Modeling of a Residential Building**” submitted by **Abdullah Al-Ferdous**, ID: CEN 060 09263; **Based Mia**, ID: CEN 060 09206; **Rashel Mahmud**, ID: CEN 060 09265 and **Md. Sahinur Rahman**, ID: CEN 060 09280, students of the Department of Civil Engineering has been examined thoroughly and accepted as partial fulfillment of the requirements for the degree of Bachelor of Science (B. Sc.) in Civil Engineering on 12<sup>th</sup> September, 2020.

---

**(Md. Mahbub-ul-Alam)**

Supervisor, Project & Thesis and  
Associate Professor  
Department of Civil Engineering  
Stamford University Bangladesh.

# DECLARATION

We, **Abdullah Al-Ferdous, Based Mia, Rashel Mahmud** and **Md. Sahinur Rahman**, are the students of B.Sc. in Civil Engineering, hereby solemnly declare that the works presented in this project & thesis has been carried out by us and has not previously been submitted to any other University / College / Organization for any academic qualification / certificate degree.

We warrant that the present work does not breach any existing copyright and no portion of this project & thesis is copied from any work.

We further undertake to indemnify the University against any loss or damage arising from breach of the fore going obligations.

---

**Abdullah Al-Ferdous**  
ID: CEN 060 09263  
Batch No. 60(A).  
Department of Civil Engineering

---

**Based Mia**  
ID: CEN 060 09206  
Batch No. 60(A).  
Department of Civil Engineering

---

**Rashel Mahmud**  
ID: CEN 060 09265  
Batch No. 60(A).  
Department of Civil Engineering

---

**Md. Sahinur Rahman**  
ID: CEN 060 09280  
Batch No. 60(A).  
Department of Civil Engineering



## ACKNOWLEDGEMENT

The research works “**Structural Modeling of a Residential Building**” has been conducted in partial fulfillment of the requirements for the degree of Bachelor of Science (B.Sc.) in Civil Engineering. This critical works became possible for us due to the unconditional help and co-operation in different ways by many people. We express our gratefulness and thanks to them for their assistance in preparation of this project and thesis.

First of all, we like to show our highest gratitude to the Almighty Allah for His kindness on us that make it possible to complete the study and preparation of this project and thesis.

We are very much grateful to our supervisor, Md. Mahbub-ul-Alam, Associate Professor of the Department of Civil Engineering, Stamford University Bangladesh for his sincere cooperation and sufficient time for discussions and continuous suggestions.

We are indebted to Prof. Dr. B.C. Basak, the Chairman of the Department of Civil Engineering, Stamford University Bangladesh for giving us patient hearing, sufficient time for discussions and continuous suggestions and guidance for preparation of this ‘Project and Thesis’. He is also our respected teacher who helped us a lot in many ways unlimitedly not only in preparation of this project and thesis but also to fulfill the requirements for earning the degree of B.Sc. in Civil Engineering.

We are also grateful to all of our teachers of the university for their co-operation and dedicated teaching for the achievement of the degree of B.Sc. in Civil Engineering. Co-operation and assistance of all the officers and staffs of the Stamford University Bangladesh are healthfully acknowledged. Also we are thankful to them who helped us in making 3-d model of the structure as used in this study.

## **ABSTRACT**

This study was carried out in the Department of Civil Engineering of Stamford University Bangladesh with the objectives of obtaining knowledge on design of Edge Supported Wall-Frame Residential.

Major cities, Specially Dhaka have been witnessing a renaissance in urban development. One of the current development patterns is a steady demand for urban projects due to continuous city migration by empty nesters and young professionals. Concerns over sprawl, traffic congestion and higher energy price will accentuate the desirability of urban living environments. This reflects a global trend taking place in major international cities due to demographic changes and rediscovery of center city living creating a need for more urban residential housing.

But what is driving this boom in high rise living? Major demographic shifts, life-style, health choices, environmental awareness, sustainability, investments in real estate and smart growth principles are contributing factors to the rise in a demand for more high-rise residential living. These issues are not only changing the way we live, but they are impacting and reinventing how we build high rise residential buildings.

High-rise residential buildings became possible with the invention of the elevator (lift) and cheaper, more abundant building materials. The materials used for the structural system of high-rise buildings are reinforced concrete and steel. High-rise structures pose particular design challenges for structural and geotechnical engineers, particularly if situated in a seismically active region or if the underlying soils have geotechnical risk factors. They also pose serious challenges to firefighters during emergencies in high-rise structures. Wind load impacts are to be carefully considered during design.

Despite the drive to meet a growing demand for housing by building faster and cheaper, a movement has begun to “raise the bar” on the quality of high-rise residential architecture from both performance and design aesthetic viewpoints. This study focuses all issues while planning and design the proposed model of the residential building.

## **TABLE OF CONTENTS**

<b>Title</b>	<b>Page</b>
ACKNOWLEDGEMENT	i
ABSTRACT	ii
TABLE OF CONTENTS	iii
LIST OF FIGURES	v
LIST OF TABLES	vii
<b>CHAPTER 1: INTRODUCTION</b>	
1.1 General	1
1.2 Background of the study	1
1.3 Objective of the Study	2
1.4 Scopes of the Study	2
<b>CHAPTER 2: LETERETURE REVIEW</b>	
2.1 Seismic design requirements of RCC Beams	3
2.2 Seismic Considerations for Column Design	6
2.3 Shear wall design considerations	10
2.4 Wall-frame Structure	15
2.5 Water requirement as per BNBC	15
2.6 Details of Lift and Escalator as per BNBC	17
2.7 Ramp, Parking and Stair	21
2.8 Wind Loads	24
2.9 Earthquake Loads	26
<b>CHAPTER 3: METHODOLOGY</b>	
3.1 General	36
3.2 Study Procedures	36



## **CHAPTER 4: DETAILS OF PROPOSED BUILDING**

4.1	Introduction	37
4.2	Details of Load and Materials Properties	37
4.3	Floor Plan Details	44
4.4	Structural Details of Building	49
	Detailing of Slab	49
	Detailing of Beam	50
	Detailing of Column	58
	Detailing of Stair	64
	Detailing of Ramp	69
	Detailing of Lift Core (Shear Wall)	73
	Detailing of Overhead Water Tank	75
	Detailing of Underground Water Reservoir	77

## **CHAPTER 5: CONCLUSIONS & RECOMMENDATIONS**

5.1	Conclusions	88
5.2	Recommendations	88

<b>REFERENCES</b>	89
-------------------	----

## LIST OF FIGURES

<b>Figure no.</b>	<b>Figure name</b>	<b>Page</b>
2.1a	Arrangement of Transverse Reinforcement in RCC Beam	5
2.1b	Details of Transverse Reinforcement	5
2.2	Seismic Requirements of Column	9
2.3	Shear wall with Typical Reinforcement Arrangement	14
2.4	Shear Wall-Rigid Frame Structure	15
4.1a	3D view of the building	39
4.1b	3D Back view of the building	40
4.1c	3D Right view of the building	41
4.1d	Left side View of Building	42
4.2	3D Structural View (frame) as per ETABS	43
4.3	Floor Plan Details of Basement Floor	45
4.4	Floor Plan Details of Ground Floor	46
4.5	Floor Plan Details of 1 <sup>st</sup> and 17 <sup>th</sup> Floors	47
4.6	Floor Plan Details of Roof	48
4.7a	Slab detailing of 16 <sup>th</sup> Floor	49
4.7b	Slab detailing of 16 <sup>th</sup> Floor (partial)	50
4.8	Floor beam layout of 6 <sup>th</sup> floor	51
4.9a	Longitudinal Section Reinforcement of Beam	55
4.9b	Cross Section at three locations of Beam	56
4.9c	Details of Closed Hoop and Cross Stirrup of Beam.	57
4.10	Floor column layout	58
4.11a	Details of Longitudinal Section	62
4.11b	Details of Cross Sections, Ties and Closed Hoops	63
4.12a	Stair Plan	64
4.12b	Stair Elevation	64
4.13	Details of reinforcement arrangement (stair)	68
4.14	Details of reinforcement arrangement (ramp)	72
4.15	Wall Layout Plan	73

4.16a	Lift Core Section (At GF Floor Level)	74
4.16b	Reinforcement arrangement of Spandrel (At GF Floor Level)	74
4.17	Overhead Water Tank Layout Plan	75
4.18	Reinforcement details of Over Head Water Tank wall cross section.	76
4.19a	Slab detailing OWT (Top)	76
4.19b	Slab detailing OWT (Bottom)	77
4.20	Underground Water Reservoir Layout Plan	77
4.21a	Details of reinforcement arrangement of Wall of the underground water reservoir.	85
4.21b	Details of section A-A of the underground water reservoir.	85
4.21c	Details of section B-B of the underground water reservoir.	86
4.22a	Reinforcement details of bottom slab of the underground water reservoir.	86
4.22b	Reinforcement details of top slab of the underground water reservoir.	87

## LIST OF TABLES

<b>Table no.</b>	<b>Table name</b>	<b>Page</b>
2.1	Guideline for water requirement for various occupancies and facility groups in LPCD	15
2.2	Fire Protection for fire requirements	16
2.3	Maximum inside net platform areas for various rated loads	18
2.4	Car speed for lift in different kinds of usage	19
2.5	Maximum interval and minimum 5-minute handing capacity for different occupancy	20
2.6	Occupant load for estimation of population	20
2.7	Minimum pit depths for traction lifts-overhead machine	21
2.8	Minimum parking requirement for various occupancies	22
2.9	Limiting Dimensions of the Staircase	23
2.10	Basic wind speed for selected locations in Bangladesh	25
2.11	Vertical Irregularities of structures	27
2.12	Plan Irregularities of structures	28
2.13	Zone Coefficient, Z	30
2.14	Structure Importance Coefficient	30
2.15	Structure Important Categories	31
2.16	Response Modification Coefficient for Structure system, R	32
2.17	Site Coefficient, S for the seismic Lateral Forces	33
4.1	Summary of the design considerations and specification of the study	37
4.2a	Details of Longitudinal Reinforcement (Bottom)	52
4.2b	Details of Longitudinal Reinforcement (Top)	52
4.3	Details of Shear Reinforcement	52
4.4	Longitudinal reinforcement of column	58
4.5	Transverse/Shear Reinforcement of Column	59

# CHAPTER 1

## INTRODUCTION

### 1.1 General

An apartment tower, residential tower, apartment block, block of flats is a tall building or structure used as a residential building. In some areas, such a structure is referred to as an apartment building, while a group of such buildings is called an apartment complex. The planning and design of current modern residential building needs careful thought and more concentration on safety of the structure. This study will try focuses on such modern design criteria.

### 1.2 Background of study

Major cities, specially Dhaka have been witnessing a renaissance in urban development. One of the current development patterns is a steady demand for urban projects due to continuous city migration by empty nesters and young professionals. Concerns over sprawl, traffic congestion and higher energy price will accentuate the desirability of urban living environments. This reflects a global trend taking place in major international cities due to demographic changes and rediscovery of center city living creating a need for more urban residential housing.

But what is driving this boom in high rise living? Major demographic shifts, life-style, health choices, environmental awareness, sustainability, investments in real estate and smart growth principles are contributing factors to the rise in a demand for higher rise residential living. These issues are not only changing the way we live, but they are impacting and reinventing how we build high rise residential buildings.

High-rise residential buildings became possible with the invention of the elevator (lift) and cheaper, more abundant building materials. The materials used for the structural system of high-rise buildings are reinforced concrete and steel. High-rise structures pose particular design challenges for structural and geotechnical engineers, particularly if situated in a seismically active region or if the underlying soils have geotechnical risk factors. They also pose serious challenges to firefighters during emergencies in high-rise structures. Wind load impacts are to be carefully considered during design.

Despite the drive to meet a growing demand for housing by building faster and cheaper, a movement has begun to “raise the bar” on the quality of high rise residential architecture from both performance and design aesthetic viewpoints. This study focuses all issues while planning and design the proposed model of the residential building.

### **1.3 Objectives and the study**

- How to plan a residential with high rise floors.
- How to allocate modern amenities & services such as Passenger Elevator, Car Parking, for a Residential high rise structure.
- How to design different structural elements such as beams, columns, shear wall, ramp etc. as per lateral loads requirements of BNBC & ACI Codes.

### **1.4 Scopes/limitations of the study**

1. This study had been made based on High rise structural design concept. Following parameters were not considered in the design of the structure:
  - ▶ Deflections and sway effects
  - ▶ Design of beam-column joints
2. Edge supported floor system was considered.
3. ETABS-2016 was used for analysis, design & detailing.
4. Stair, overhead water tank, Underground water reservoir, etc. were designed manually.
5. Architectural Plan was done according to BNBC code.
6. Plumbing, electrification, brick works etc. were not considered.
7. Estimation & Cost analysis of the structure were not done.
8. Foundation was not considered in design.

## CHAPTER 2

# LITERATURE REVIEW

### 2.1 Seismic design requirements of RCC Beams

#### *# Material Strength*

- Minimum specified compressive strength of all types of concrete,  $f_c' = 3,000 \text{ psi}$
- Maximum specified compressive strength of light-weight concrete,  $f_c' = 5,000 \text{ psi}$
- Maximum specified yield strength of reinforcement,  $f_y = 60,000 \text{ psi}$

#### *# Clear span of the beam*

- Clear span  $>$  four times the effective depth i.e.  $l_n > 4d$

#### *# Sectional dimensions of the beam*

- Width-to-depth ratio  $\geq 0.3$  i.e.  $b/h \geq 0.3$
- Minimum width  $\geq 10 \text{ inch}$
- Minimum width of the beam  $\leq [\text{width of the supporting column} + 1.5h]$

#### *# Main reinforcement*

- $\rho_{min} \geq 200/f_y$
- $\rho_{max} \leq 0.0250$
- Two continuous bars should be at both top and bottom of the member.
- At any section, the top or bottom steel should not be less than  $\frac{1}{4}$  of the steel for the maximum  $-ve$  moment at the supports.
- At each support, minimum bottom  $+ve$  steel must be equal to  $\frac{1}{2}$  of the  $-ve$  moment steel.

#### *# Splicing of the Main reinforcement*

- Splice shall not be used (i) within joints (ii) within  $2h$  from the column face.
- Splices are to be confined by hoops or spiral reinforcement with maximum spacing or pitch of  $d/4$  or  $4 \text{ inch}$  whichever is smaller.

### # *Transverse reinforcement details*

Such reinforcement (details in Figure 2.1a) is provided in the form of a closed hoop with cross tie(s) and must satisfy the following requirements:

- Total required steel area  $A_v = \frac{V_u}{f_y \times d} \times s$
- Confinement reinforcement is provided in the form of hoops, as shown in figure 2.1b.
- Hoops are required over a distance  $2h$  ( $h$  = depth of beam) from faces of both supports.
- First hoop will be placed at  $2 \text{ inch}$  from face of support.
- Maximum hoop spacing is the smaller of the followings:
  - i)  $d/4$
  - ii) 8 x diameter of smallest longitudinal bar
  - iii) 24 x diameter of the hoop bar
  - iv)  $12 \text{ inch}$
- Where hoops are not required (beyond confinement zone and splicing), stirrups with seismic hooks at both ends (detail A) shall be spaced not more than  $d/2$  throughout the length of the member.



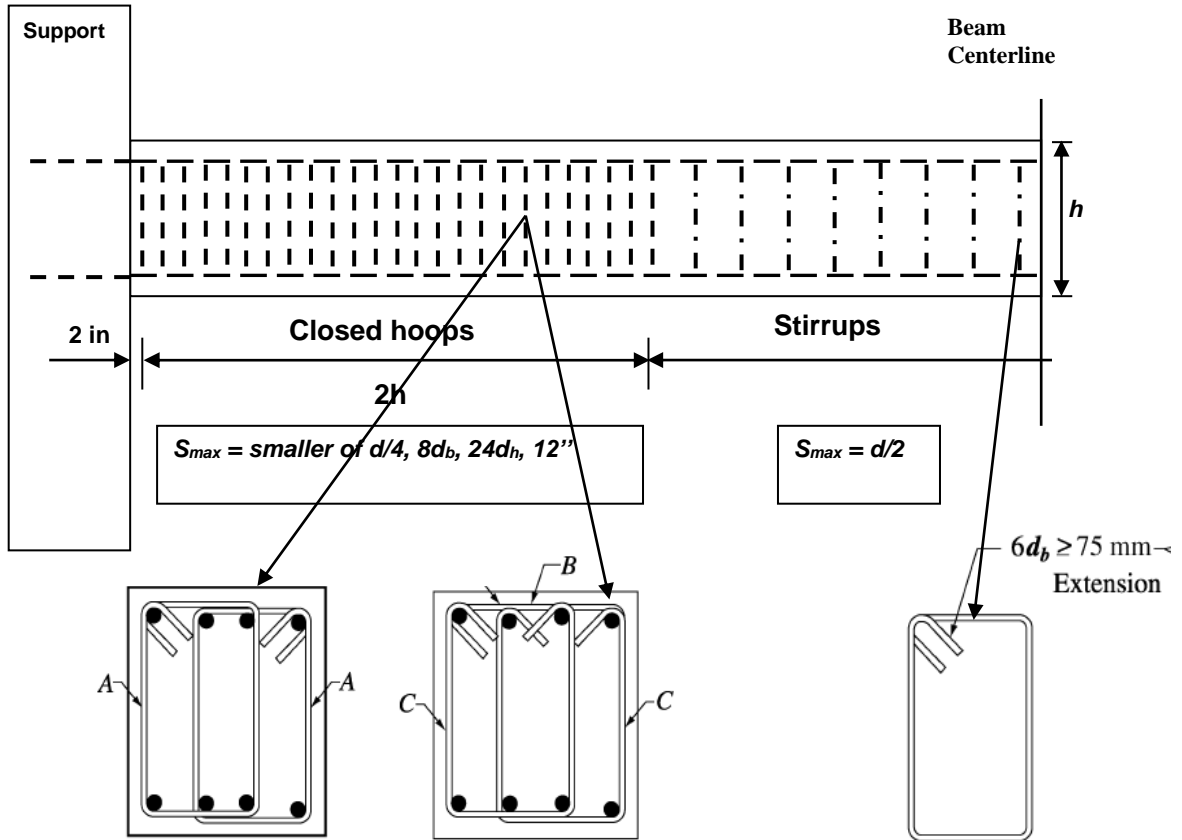

Figure 2.1a: Arrangement of Transverse Reinforcement in RCC Beam

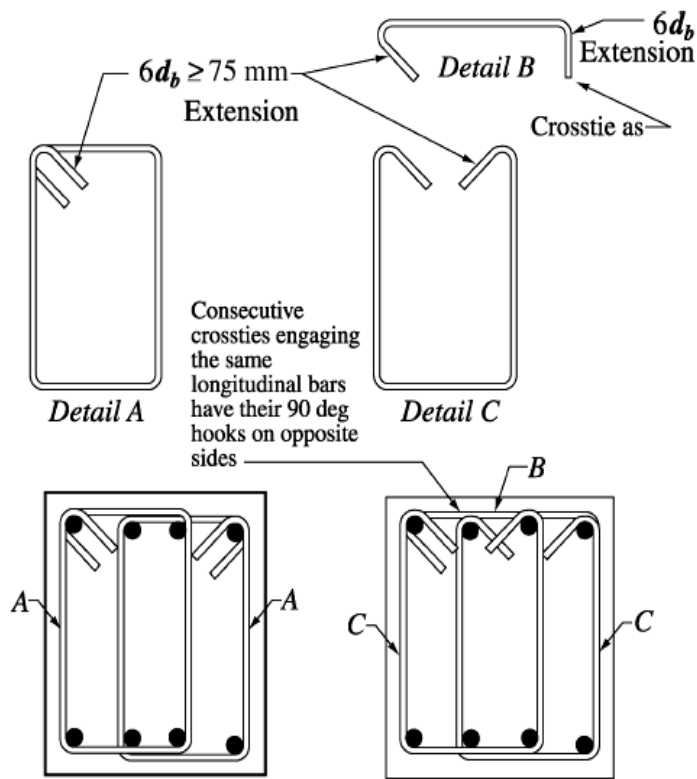

Figure 2.1b: Details of Transverse Reinforcement

## 2.2 Seismic Considerations for Column Design

### *Material Strength*

- Minimum compressive strength of all types of concrete,  $f_c' = 3,000 \text{ psi}$
- Maximum compressive strength of light-weight concrete,  $f_c' = 5,000 \text{ psi}$
- Maximum yield strength of reinforcement,  $f_y = 60,000 \text{ psi}$
- Normal density concrete is preferable,  $w_c = 140\sim 150 \text{ pcf}$

### *Sectional dimensions of the column*

- Width-to-depth ratio  $\geq 0.4$  i.e.  $b/h \geq 0.4$
- Least dimension  $\geq 12 \text{ inch}$

### *Main reinforcement ratio*

- $\rho_{min} = 0.01$
- $\rho_{max} = 0.06$
- Preferable  $\rho = 0.04$

### *Splicing of the Main reinforcement*

- Lap splice shall be used only within the center of the column.
- Welded splices may be used at any section of column, provided that:
  - a) They are used only alternate longitudinal bars at a section
  - b) The distance between splices along the longitudinal axis of reinforcement  $\geq 24"$
- Splices are to be confined by hoops or spiral reinforcement with maximum spacing or pitch of  $d/4$  or  $4 \text{ inch}$  whichever is smaller.
- Splice length:

Splice length =  $1.3 l_d$  (class B splice)

Where,  $l_d$  = development length of the bars

$$l_d \geq \left\{ \begin{array}{l} \frac{0.04 A_b f_y}{\sqrt{f_c'}}, A_b = \text{Bar area} \\ 0.0004 d_b f_y \\ 12'' \end{array} \right\}$$

### **Transverse reinforcement**

Such reinforcement is provided as closed hoops for tied column or circular hoops for spiral column.

a) **Circular hoops**: steel ratio of circular/spiral hoops,

$$\rho_s \geq \left\{ \begin{array}{l} 0.12 \frac{f'_c}{f_{yh}} \\ 0.45 \left( \frac{A_g}{A_{ch}} - 1 \right) \frac{f'_c}{f_{yh}} \end{array} \right\}$$

Where,

$f_{yh}$  = yield strength of hoop reinforcement.

$A_{ch}$  = core area of column section measured to the outside of hoop reinforcement.

b) **Closed hoops**: Total cross-sectional area of closed hoops,

$$A_{sh} \geq \left\{ \begin{array}{l} 0.09 s_o h_c \frac{f'_c}{f_{yh}} \\ 0.3 s_o h_c \left( \frac{A_g}{A_{ch}} - 1 \right) \frac{f'_c}{f_{yh}} \end{array} \right\}$$

Where,

$h_c$  = cross-sectional dimension of column core measured center-to-center of hoop reinforcement.

$s_o$  = vertical spacing of hoop reinforcement.

- **Confinement length**: confinement reinforcement is to be provided over a length  $l_o$  from each joint face.

$$l_o \geq \left\{ \begin{array}{l} \frac{1}{6} (\text{clearspan of the column}) \\ \text{depth of member} \\ 18'' \end{array} \right\}$$

First hoop will be placed at 2 inch from the joint.

- **Spacing of the hoops:**

$$s_o \leq \left\{ \begin{array}{l} \frac{1}{4}(\text{least member dimension}) \\ 6d_b \\ s_x = 4 + \frac{14 - h_x}{3}; 4'' \leq s_x \leq 6'' \end{array} \right\}$$

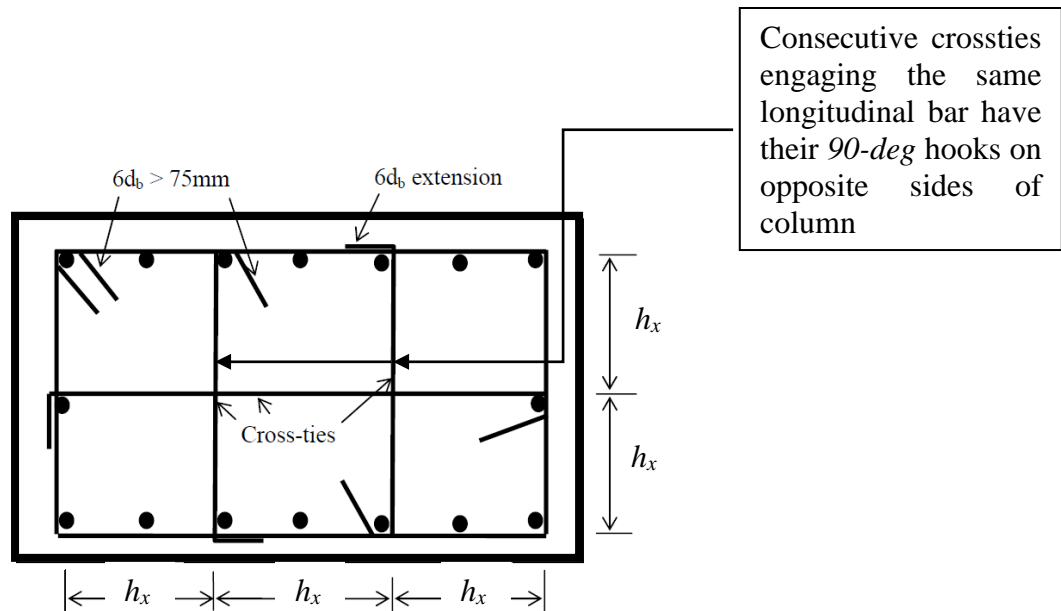

Where,

$h_x$  = maximum horizontal spacing of hoop or cross-tie legs on all faces of the column  $\leq 14''$ .

- **Special Notes:**
  - a) If column support shear wall, confinement reinforcement is to be provided over the full height of the column.
  - b) If column terminates on a footing, confinement reinforcement shall extend at least 12" into the footing.
  - c) Beyond the length  $l_o$  and splice length, the maximum spacing of tie or pitch of spiral will be,

$$s \leq \left\{ \begin{array}{l} 6d_b \\ 6'' \end{array} \right\}$$

A detail of seismic requirements for column is shown in Figure 2.2.

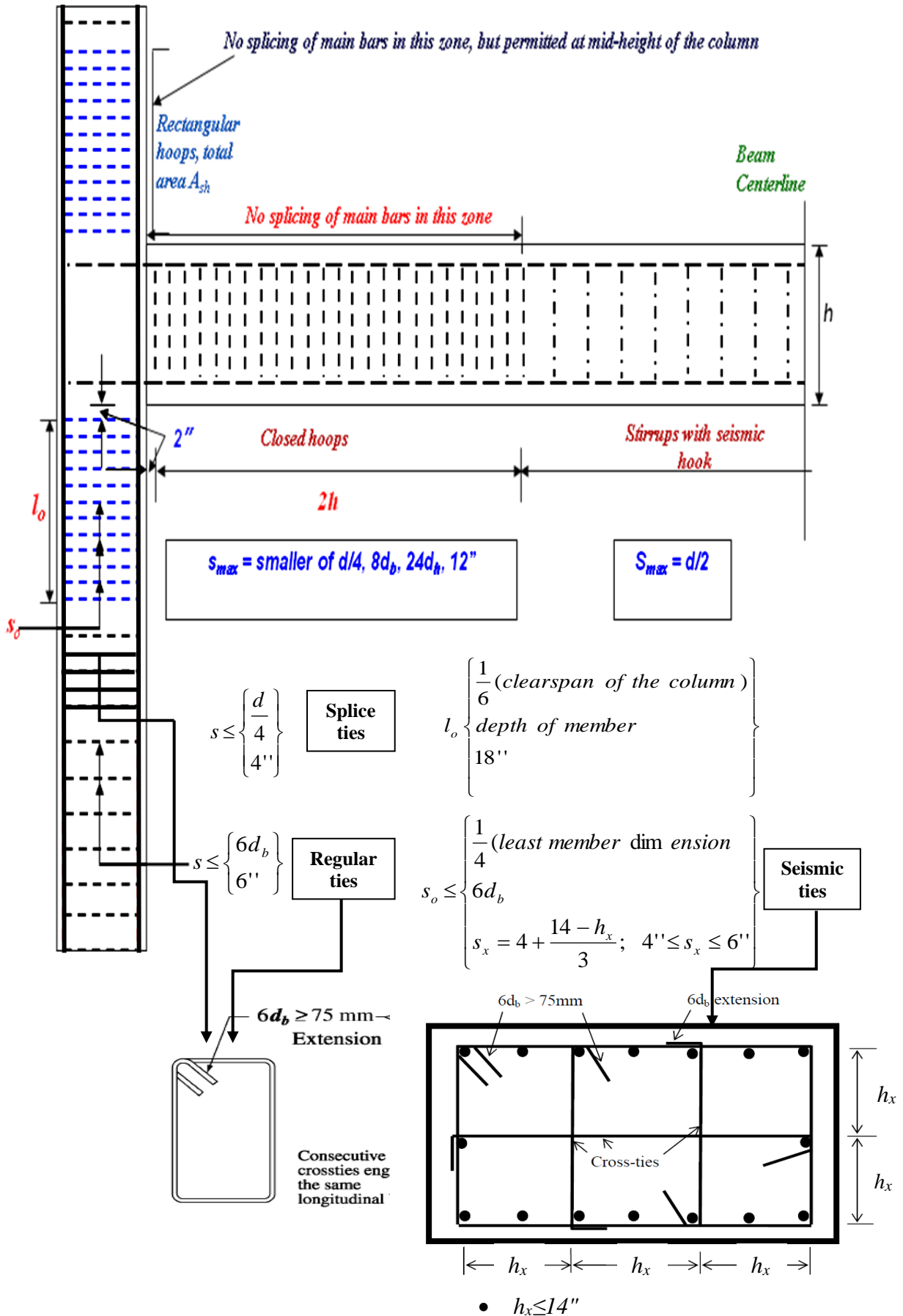
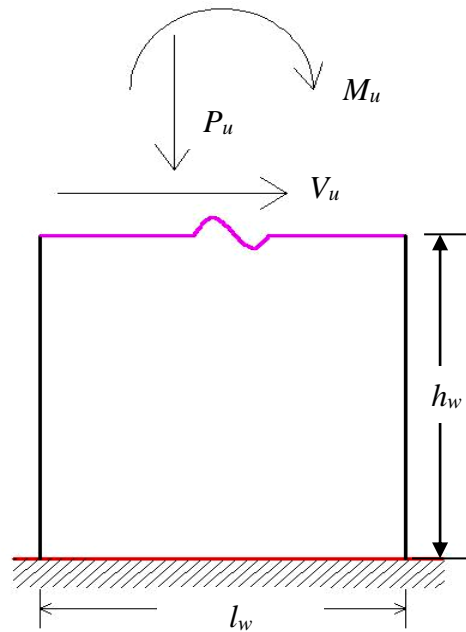

Figure 2.2: Seismic Requirements of Column

### 2.3 Shear wall design considerations

A shear wall may be subjected to the following forces. The typical design procedure of a shear wall is presented here as per ACI code.



#### Step-1: Calculate External Load

$M_u$

$V_u$  » These can be obtained by software analysis.

$P_u$

#### Step-2: Boundary element check

$$I_g = \frac{bh^3}{12} = \frac{b_w l_w^3}{12}$$

$$f_c = \frac{P}{A} \pm \frac{MC}{I_g}$$

If  $f_c < 0.2f'_c$ , then boundary element will not be required.

If  $f_c \geq 0.2f'_c$ , then boundary element will be required.

#### Step-3: Obtain the dimension of the shear wall

Length of the shear wall =  $l_w$

Width of the shear wall =  $b_w$

Height of the shear wall =  $h_w$

#### Step-4: Determine the dimension of the boundary element

As per following figure, calculate:

Thickness of the boundary element =  $b_b$

Length of the boundary element =  $l_b$

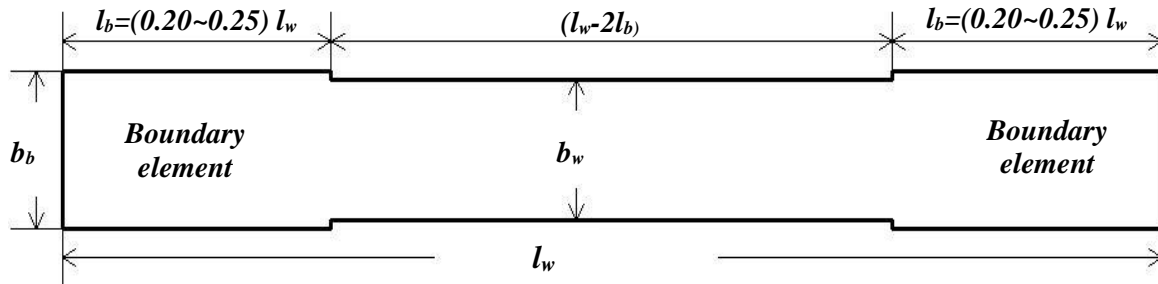

Also remember the following conditions:

- The minimum section dimension of the boundary zone shall be  $l_w/16$  i.e.  $b_b \geq l_w/16$  and  $l_b \geq l_w/16$ .
- Boundary zones shall have a minimum length of 18 inches (measured along the length) at each end of the wall i.e.  $l_b \geq 18"$ .

#### Step-5: Check requirement of longitudinal & transverse reinforcements

According to the ACI code, two sets of reinforcement curtains, each having bars running in the longitudinal and transverse directions, will be required

- If  $\frac{A_{cv} \times \sqrt{f'_c}}{6} < V_u$ , where  $A_{cv} = l_w b_w$
- If thickness of the wall  $> 10"$ .

#### Step-6: Calculate the longitudinal & transverse reinforcements

**Steel ratios:**

$$* \text{if } V_u > \frac{A_{cv} \sqrt{f'_c}}{6},$$

$$\rho_v = 0.0025 \quad \& \quad \rho_h = 0.0025$$

$$* \text{if } V_u \leq \frac{A_{cv} \sqrt{f'_c}}{6},$$

for bar  $\leq \phi 16$  :

$$\rho_v = 0.0012 \quad \& \quad \rho_h = 0.0020$$

for bar  $> \phi 16$  :

$$\rho_v = 0.0015 \quad \& \quad \rho_h = 0.0025$$

**Total steel areas:**

Total longitudinal reinforcement per feet of wall,  $A_{sv} = \rho_v \times 12 \times b_w$

Total transverse reinforcement per feet of wall,  $A_{sh} = \rho_h \times 12 \times b_w$

**Spacing:**

Required spacing of bars having areas  $A_b$  per feet of wall [in two curtains,  $A_v = 2A_b$ ]:

$$S = \frac{A_v \times 12}{A_s}$$

**Maximum spacing:**

$S_{\max}$  will be smaller of the followings:

$$S_{\max} = 3h = 3b_w$$

$$S_{\max} = \frac{l_w}{5}$$

$$S_{\max} = 18''$$

**Step-7: Check shear strength of concrete of wall to prevent  $V_u$** 

- For walls with a height-to-width ratio  $h_w/l_w \geq 2.0$ , the shear strength of concrete is to be determined using the expression:

$$\phi V_n = \phi A_{cv} (2\sqrt{f'_c} + \rho_n f_y)$$

Where,

$\phi = 0.60$ , unless the nominal shear strength provided exceeds the shear corresponding to development of nominal flexural capacity of the wall.

$A_{cv}$  = net area =  $l_w b_w$

$h_w$  = height of entire wall or of segment of wall considered

$l_w$  = width of wall (or segment of wall) in direction of shear force

$\rho_n$  = reinforcement ratio in per foot of wall corresponding to plane perpendicular to plane of  $A_{cv}$

$$= \frac{2 \times \text{area of the selected horizontal bar}}{b_w \times 12}$$

- For walls with  $h_w/l_w < 2.0$ , the shear strength of concrete may be determined from

$$\phi V_n = \phi A_{cv} (\alpha_c \sqrt{f'_c} + \rho_n f_y)$$



Where the coefficient  $\alpha_c$  varies linearly from a value of 3.0 for  $h_w/l_w = 1.5$  to 2.0 for  $h_w/l_w = 2.0$ .

Where the ratio  $h_w/l_w < 2.0$ ,  $\rho_v$  cannot be less than  $\rho_h$ .

### Step-8: Reinforcement for boundary elements

Determine  $\frac{M_u}{A_g \times l_w}$  and  $\frac{P_u}{A_g}$

From interaction diagrams, corresponding  $\frac{P_u}{A_g}$  and  $\frac{M_u}{A_g \times l_w}$  value, reinforcement ratio  $\rho$  can be obtained.

Total reinforcement required for the shear wall,  $A_s = \rho A_g$

Therefore, reinforcement required for boundary element

= Total steel requirement – vertical reinforcement required for non-boundary elements

$$A_{sb} = A_s - A_{sv}$$

For each boundary element, use  $A_v = \frac{A_{sb}}{2}$

Minimum  $A_v$  should be larger of the followings:

$$A_v > \begin{cases} 0.005 \times \text{area of the boundary zone} \\ 2\#5 \text{ bars at each edge of the boundary zone} \end{cases}$$

### Step-9: Design of Transverse reinforcement for boundary elements

#### Spacing, $S_o$ :

Transverse reinforcement spacing will be the smaller of the followings:

*First condition*

$$S_o = \frac{\text{min imum dim ension of wall}}{4}$$

*Second condition*

$$S_o = 6d_b$$

*Third condition*

$$S_x = \frac{14 - h_x}{3} + 4; 4" \leq S_x \leq 6"$$

Maximum spacing will be smaller of the followings:

$$S_{max} = \begin{cases} 6'' \\ 6 \times \text{dia of largest vertical bar} \end{cases}$$

**Total steel area  $A_{sh}$ :**

Total transverse reinforcement in long or short direction will be larger of the followings:

$$A_{sh} > 0.09 \times S_o \times h_c \times \frac{f_c'}{f_{yh}}$$

$$A_{sh} > 0.30 \times S_o \times h_c \times \left( \frac{A_g}{A_{ch}} - 1 \right) \times \frac{f_c'}{f_{yh}}$$

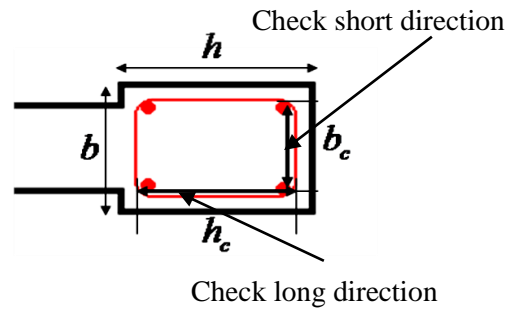

Where,

$h_c$  = cross-sectional dimension of boundary element core measured center-to-center of hoop reinforcement.

$S_o$  = vertical spacing of hoop reinforcement.

$f_{yh}$  = yield strength of hoop reinforcement.

$A_{ch}$  = core area of boundary element section measured to the outside of hoop reinforcement.

$A_g$  = gross area of boundary element section.

Typical reinforcement arrangement in a shear wall is shown in Figure 2.3

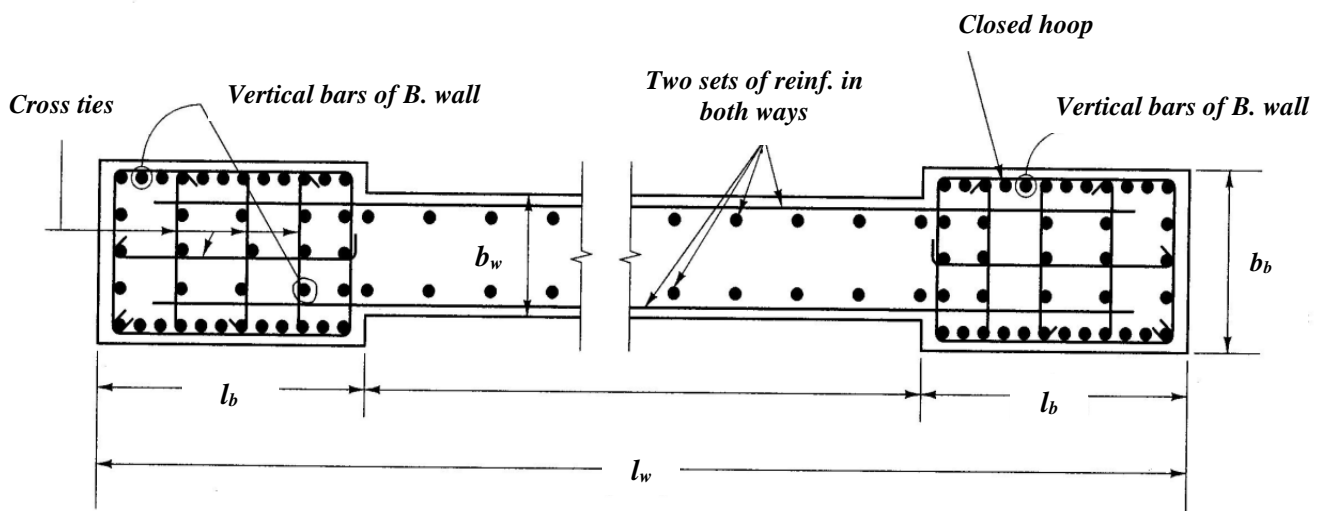

Figure 2.3: Shear Wall with Typical Reinforcement Arrangement

## 2.4 Wall-frame structure

It is a combination from shear walls and rigid frames, as shown in Figure 2.4. In this combination, the walls tend to deflect in a flexural configuration and the frames tend to deflect in shear mode are constrained to adopt a common deflected by a horizontally rigidity of the girders and the slabs. As a consequence, the walls and the frames interact horizontally, especially at the top, to produce stiffer and stronger structure. The interacting wall –frame combination is appropriate for buildings in the 40 to 60 storey range, well beyond that of rigid frames or shear walls alone.

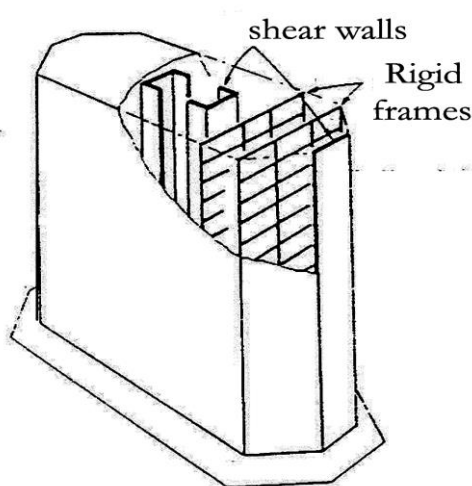

Figure 2.4: Shear Wall-Rigid Frame Structure

## 2.5 Water Requirements as per BNBC

### Water Requirement for Domestic Use

Water requirements for daily domestic use of a building shall be assessed on the basis of the one or a combination of the following two methods:

- a) Number of occupants according to their occupancy classification and their water requirements as specified in Table 2.1.
- b) Peak demand or maximum probable flow.

**Table 2.1: Guideline for Water Requirements for Various Occupancies and Facility-Groups in Litres Per Capita Per Day (LPCD)**

Class of Occupancy	Occupancy Groups	For Full <sup>a</sup> Facilities (LPCD)	For Restricted Facilities (LPCD)
Occupancy A: Residential	A1: Single Family Dwelling	400	135
	A2: Flats or Apartments	225	135
	A3: Mess, Hostels, or Boarding House	135	70
	A4: Minimum Standard Housing	-	70
	A5: Hotels or Lodging House (Per bed)	300	135

Occupancy B: Educational	B1: Educational Facilities	70	45
	B2: Preschool Facilities	50	35
Occupancy C: Institutional	C1: Institution for Children's Care	180	100
	C2: Custodian Institution for Capable	180	100
	C3: Custodian Institution for Incapable	120	70
	C4: Penal and Mental Institution	120	70
Occupancy D: Health Care	D1: Normal Medical Facilities	450	225
	D2: Emergency Medical Facilities	300	135
Occupancy E: Assembly	E1: Large Assembly with Fixed Seats (per seat)	90	45
	E2: Small Assembly with Fixed Seats (per seat)	90	45
	E3: Large Assembly without Fixed Seats <sup>b</sup>	8	5
	E4: Small Assembly without Fixed Seats	8	5
	E5: Sports Facilities	8	5
Occupancy F: Business and Mercantile	F1: Offices	45	30
	F2: Small Shops and Markets	45	30
	F3: Large Shops and Markets	45	30
	F4: Garage and Petrol Stations	70	45
	F5: Essential Services	70	45
Occupancy G: Industrial	G1: Low Hazard Industries	40	25
	G2: Moderate Hazards Industries	40	25
Occupancy H: Storage	H1: Low Fire Risk Storage	10	6
	H2: Moderate Fire Risk Storage	10	6
Occupancy J: Hazardous	J1: Explosive Hazard Building	8	5
	J2: Chemical Hazard Building	8	5
Occupancy K <sup>c</sup> Miscellaneous	K1: Private Garage & Special Structure	8	5
	K2: Fences, Tanks and Towers	-	3
a For full facility in occupancy classifications A, B, C and D, the water requirement value includes 25% hot water.			
b In the case of mosques, the water requirements given above shall be adequate for ablution and other uses of one devotee per prayer. The appropriate LPCD value may be calculated on this basis.			
c Water requirement for occupancy K is shown as a provision for unknown visitors only.			

### **Water Requirement for Fire Fighting**

The water requirement for firefighting shall be in accordance with Table 2.2.

**Table 2.2: Fire Protection Flow Requirements**

<b>Building Type</b>	<b>Sprinkler System (l/min.)*</b>	<b>Standpipe and hose System (l/min.)*</b>	<b>Duration** (minute, min.)</b>
Light hazard- I	1000	1000	30
Light hazard- II	1900	1900	50
Ordinary hazard- I	2650	1900	75
Ordinary hazard - II	3200	1900	75
Ordinary hazard - III	4800	1900	75

**Notes:**

- \* Values will be for one riser serving floor area of 1000 m<sup>2</sup>.
- \*\* These durations shall be for a building up to the height of 51m. For greater height of 51-102m and above 102m, the duration will be 1.25 times and 1.5 times of the specified values respectively.
- Light hazard - I : Occupancy groups, A1, A2, A4
- Light hazard - II : Occupancy groups, A3, A6, A7, A8, B, C, D, E2, E4, E7, F1 & F2
- Ordinary hazard - I : Occupancy groups, E1, E3, E5, F3, F4, F5, F6, F7, G1 & G4
- Ordinary hazard- II : Occupancy groups, G2 & H1
- Ordinary hazard- III : Occupancy groups, G3 & H2

**2.6 Details of LIFT as per BNBC****Location:**

- Lifts shall be provided in buildings more than six storeys or 20 m in height.
- For maximum efficiency, they shall be grouped near the center of the building. Walking distance from the lift to the farthest office or suite shall not exceed 60 m.
- In multi-story residential buildings, hotels and hospitals, lift well shall be isolated from sleeping rooms (bed rooms) by lobbies or other spaces.

**Details of Lift Cars:**

- The roof, solid or perforated, shall be capable of supporting two persons or a minimum load of 150 kg.
- A handrail shall be provided on at least one wall of the car, preferably the rear. The rails shall be smooth and the inside surface at least 38 mm clear of the walls at a nominal height of 800 mm from the floor.
- The centreline of the alarm button and emergency stop switch shall be at a nominal height of 890 mm, and the highest floor button no higher than 1.37 m from the floor. Floor registration buttons, exclusive of border, shall be a minimum of 18 mm in size, raised, flush or recessed.
- The centre line of the hall call buttons shall be at a nominal height of 1 m above the floor.
- The centerline of the fixture shall be located at a minimum of 1.8 m from the floor.
- Height of the entrance to the lift car shall not be less than 2 m.
- Door reopening devices shall remain effective for a period of not less than 20 seconds. The operating mechanism for the car door shall not exert a force more than 125 N.

- In case of passenger lifts, solid sliding doors shall preferably be provided for buildings above six storeys or 20 m in height. Solid swing doors may also be used where sliding space is not available parallel to the entrance door. Collapsible doors shall not be provided in case of buildings above eight storey or 26 m in height.
- The floor designation shall be provided at each lift well entrance on both sides of jamb visible from within the car and the lift lobby at a height of 1.5 m above the floor. Designations shall be on a contrasting background 50 mm high and raised 0.75 mm.
- When there are three or fewer lift cars in a building, they may be located within the same lift well enclosure. When there are four lift cars, they shall be divided in such a manner that at least two separate lift well enclosures are provided. When there are more than four lifts, not more than four lift cars may be located within a single lift well enclosure.
- Lift cars shall have net inside area for different loading capacities not more than that shown in Table 2.3.

**Table 2.3: Maximum Inside Net Platform Areas for Various Rated Loads**

Rated Load (mass) (kg)	Maximum Available Car Area (m <sup>2</sup> )	Maximum Number of Passengers	Rated Load (mass) (kg)	Maximum Available Car Area (m <sup>2</sup> )	Maximum Number of Passengers
100	0.40	1	975	2.35	14
180	0.50	2	1000	2.40	14
225	0.70	3	1050	2.50	15
300	0.90	4	1125	2.65	16
375	1.10	5	1200	2.80	17
400	1.17	5	1250	2.90	18
450	1.30	6	1275	2.95	18
525	1.45	7	1350	3.10	19
600	1.60	8	1425	3.25	20
630	1.66	9	1500	3.40	22
675	1.75	10	1600	3.56	23
750	1.90	11	1800	3.88	26
800	2.00	11	2100	4.36	30
825	2.05	12	2500	5.00	36
900	2.20	13			
Beyond 2500 kg, add 0.16 m <sup>2</sup> for each 100 kg extra					
<p><b>Note:</b> Maximum available car area = (W x D) + Available area near the car door(s) inside the car.            Where, W = Car inside width, m            D = Car inside depth, m</p>					

- The car speed for the different types of lifts in different occupancies shall normally be as given in Table 2.4. A higher or lower speed lift may be used in special cases when conditions warrant use of such lifts.

**Table 2.4: Car Speed for Lift in Different Kinds of Usage**

Type of Lift	Number of Floors	Recommended Car Speed for Different Kinds of Usage (m/s)					
		Office Building (including Professional Offices)	Hotels and Motels	Apartments, Dormitories & Residence Hall	Hospitals and Nursing Homes <sup>a</sup>	Assembly	Stores
Passenger Lift	2 to 6	0.75 to 2	0.75	0.75	1 to 2	2	0.75 to 1.5
	7 to 12	2 to 2.5	1.5	1	2 to 2.5	2.5	1.5
	13 to 20	2.5 to 3	2	2	3.5	3.5	2 to 2.5
	21 to 25 <sup>b</sup>	3 to 3.5	2.5	2.5	4	4	2.5
	26 to 30 <sup>b</sup>	3.5 to 4	3.5	2.5 to 3.5	5	5	-
	31 to 40 <sup>b</sup>	4 to 5	3.5 to 5	-	-	-	-
	41 to 50 <sup>b</sup>	5 to 6	5 to 6	-	-	-	-
	51 to 60 <sup>b</sup>	6 to 7	-	-	-	-	-
	over 60 <sup>b</sup>	9	-	-	-	-	-
Service Lift <sup>c</sup>	2 to 5	1.0					
	6 to 10	1.5					
	11 to 15	2.0					
	16 to 25	2.5					
	26 to 35	2.5					
	36 to 45	3.5					
	46 to 60	4.0					
	over 60	4.0					
<b>Notes :</b> a For Nursing Homes slower speed lifts may be used							
b For buildings of this height, local express lifts shall be used							
c Slower speed lifts may be used for heavier loads.							

- The average Interval shall not be more than shown in Table 2.6. The Travel Time shall not exceed 150 seconds.
- The passenger handling capacity (H) of a lift system for different occupancies in terms of the number of passengers to be handled in the building in a five-minute peak period shall not be less than that indicated in Table 2.5.

**Table 2.5: Maximum Interval and Minimum 5-minute Handling Capacity for Different Occupancy**

Type of Occupancy	Maximum Interval (Sec)	Minimum 5-min. Passenger Handling Capacity (H) %
Office		
Diversified offices	45	10
Diversified Single-purpose	45	11
Single-purpose	40	12
Hotels and Motels	60	10
Apartments	90	5
Dormitories, Halls of Residence	70	15
Hospitals	50	12
Long term Nursing Facilities	70	8
Educational Institutions	50	25
Assembly	50	15
Shops and stores	50	5

- For the purpose of population estimation, the density of people shall be based on the actual number of occupants, but in no case less than those specified in Table 2.6.

**Table 2.6: Occupant Load for Estimation of Population**

Type of Occupancy	Population Factor
Office	
Diversified offices	15 m <sup>2</sup> net usable area per person <sup>a</sup>
Diversified Single-purpose	13.5 m <sup>2</sup> net usable area per person
Single-purpose	12 m <sup>2</sup> net usable area per person
Hotels and Motels	1.7 people per room
Apartments	1.7 people per bedroom
Dormitories, Residence Halls	20 m <sup>2</sup> net usable area per person
Hospitals	4 people per bed
Long term Nursing Facilities	1.75 people per bed
Educational Institutions	4 m <sup>2</sup> per student
Assembly	
With fixed or movable seats and dance floor	0.60 m <sup>2</sup> per person <sup>b</sup>
Without seating facilities including dining rooms	1.5 m <sup>2</sup> per person <sup>b</sup>
Shops and stores	2 m <sup>2</sup> of net selling area <sup>c</sup>
<b>Notes :</b> a Net usable area = gross area less lift shaft and lobby space, mechanical space, columns, toilets, corridor around core, air-conditioning machinery space.	
b Population estimation shall be based on gross area (plinth area or covered area). The gross area shall include, in addition to the main assembly room or space, any occupied connecting room or space in the same storey or in the storey above and below, where entrance is common to such rooms and spaces and they are available for use by the occupants of the assembly place. No deductions shall be made in the gross area for corridors, closets or other subdivisions, the area shall include all space serving the particular assembly occupancy.	
c Net selling area is area open to the public.	



**Lift Pits:**

- Lift pits having depth more than 1.6 m shall be provided with a suitable descending arrangement to reach the lift pit.
- A lift pit shall be provided at the bottom of every lift well. The minimum depth of lift pit shall be as shown in Table 2.7.

**Table 2.7: Minimum Pit Depths for Traction Lifts - Overhead Machines**

Speed (m/s)	0.5	1	1.5	2	2.5	3	3.5	4
<u>Depth (m)</u>								
i) With restrained rope compensation	-	-	-	1.6	2.6	2.8	3.0	3.2
ii) With chain, free rope or travelling cable compensation	1.5	1.5	1.6	2.4	2.5	-	-	-
iii) With reduced stroke buffer and either restrained rope chain travelling cable or free rope compensation	-	-	1.5	1.6	2.4	2.6	2.6	2.8

**2.7 RAMP, PARKING & STAIR****A. Ramp & Basement Car Parking**

- Ramps, if provided, shall have a grade not steeper than 1 vertical to 8 horizontal.

**Private Garage:**

A private garage in a residential building shall have a minimum clear height of 2.03 m. The length of the garage shall not be less than 4.5 m. The width of the garage for a single car shall be at least 2.6 m and for two cars shall be at least 5 m.

**Basement Car Parking:**

- The clear height of the basement below soffit of beams shall not be less than 2.03 m.
- Basement floor of a building shall be enclosed with a one-hour fire resistive construction.
- A 23 m<sup>2</sup> space shall be allotted for parking of each car. The number of parking spaces required shall be based on the total floor area of the building and shall

depend on its occupancy. Parking spaces shall be provided for various occupancies at the minimum rates as per Table 2.8:

**Table 2.8: Minimum Parking requirement for various occupancies**

Occupancy	Parking Requirement
A. Residential (A1 & A2)	1 car for every 300 m <sup>2</sup>
" (A5)	1 car for every 200 m <sup>2</sup>
B. Educational	1 car for every 200 m <sup>2</sup>
C. Institutional	1 car for every 300 m <sup>2</sup>
D. Health Care	1 car for every 300 m <sup>2</sup>
E. Assembly	1 car for every 20 occupants or 100 m <sup>2</sup>
F. Business and Mercantile (F1)	1 car for every 200 m <sup>2</sup>
" (F5)	1 car for every 100 m <sup>2</sup>
G. Industrial	1 car for every 300 m <sup>2</sup>
H. Storage	1 car for every 25 occupants
J. Hazardous	1 car for every 25 occupants

- For storage and industrial buildings, required space for loading and unloading of at least one truck/lorry shall be provided.
- When administrative or sales offices are located in the industrial premises, parking space for one car for every 300 m<sup>2</sup> of the office area shall be provided in the premises.

#### **B. Stair case**

- The minimum width of the staircase for various occupancies shall be as specified in Table 2.9.
- The minimum widths of stairs serving not more than two dwelling units per floor shall be as follows :

2 - storeyed buildings	0.75 m
3 - storeyed buildings	0.80 m
4 - storeyed buildings	0.90 m
5 or 6-storeyed buildings	1.00 m

**Table 2.9: Limiting Dimensions of the Staircase**

<b>Occupancy</b>	<b>Minimum Width of Stair (m)</b>
A. Residential Buildings	
A1 Detached Single-Family Dwelling	1.0
A2 Flats or Apartments	1.15
A3 Mess, Boarding House and Hostel	1.25
A4 Minimum Standard Housing	---
A5 Hotels and Lodging Houses	1.25
B. Educational Buildings	1.5
C. Institutional Buildings	1.5
D. Health Care Buildings	2.0
E. Assembly Buildings	2.0
F. Business and Mercantile Buildings	
F1 Offices	1.5
F2 Small Shops and Markets	1.5
F3 Large Shops and Markets	2.0
F5 Essential Services	1.5
All Other Buildings	1.25

- The height of the riser shall not be more than 215 mm. The maximum number of risers per flight in a straight flight stair shall be 15.
- The minimum depth of the tread shall be as follows :
 

2 or 3-storeyed buildings	215 mm
4, 5 or 6-storeyed buildings	250 mm
- The depth of landing at any level shall be at least equal to the width of the stair.
- Combination of the riser and the tread dimensions shall be such that the sum of the riser height and the tread depth shall be between 400 mm and 425 mm with a minimum tread depth of 215 mm and a maximum riser height of 215 mm. The tread depth may include any nosing and any increase due to slant riser faces. The variation between depths of adjacent treads and heights of adjacent risers shall not exceed 5 mm. The difference between the largest and the smallest riser or between the largest and the smallest tread shall not exceed 2 per cent of the respective average dimensions in any flight of stairs.

- The minimum clear head room between flights of a staircase shall be 2.15 m. The clear head room may be reduced to 2.03 m for not more than three flights in any staircase.
- The minimum clear height of any passage below a landing providing access to non-habitable and service spaces shall be 2.03 m. The minimum clear height of all other passages and spaces below a landing shall be 2.15 m.  
Handrails shall have a minimum height of 0.9 m measured from the nose of stair to the top of the handrail.
- An enclosed staircase shall have exterior windows not less than 1 m<sup>2</sup> in area on every floor through which the stairway passes.

## 2.8 Wind Loads

The actual intensity wind pressure depends on a number of factors like angle of incidence of the wind, roughness of surrounding area, effects of architectural features, i.e. shape of the structure etc. and lateral resistance of the structure. Apart from these, the maximum design wind load pressure depends on the duration and amplitude of the gusts and the probability of occurrence of an exceptional wind in the lifetime of building.

### Code Provisions for Wind Load

The minimum design wind load on buildings and components is determined based on the velocity of the wind, the shape and size of the building and the terrain exposure condition of the site. Provisions to the calculation of design wind loads for the primary framing system and for the individual structural components of the buildings. Provisions are included for forces due to along-wind response of regular shaped building, caused by the common wind-storms including cyclones, thunderstorms and nonwestern.

#### **a. Basic Wind Speed**

The basic wind speed for the design is taken from basic wind speed map of Bangladesh (BNBC, 1993), where it is in km/h for any location in Bangladesh, having isobaths representing the fastest-mile wind speed at 10 meters above the ground with terrain exposure B for a 50 years' recurrence interval. The minimum value of the basic wind speed set in the map is 130 km / h and maximum is 260 km/h. The basic wind speed for selected locations in Bangladesh are given in Table 2.10.

**Table 2.10: Basic Wind Speeds for Selected Locations in Bangladesh**

<b>Location</b>	<b>Basic Wind Speed (km/h)</b>	<b>Location</b>	<b>Basic Wind Speed (km/h)</b>
Angarpota	150	Lalmonirhat	204
Bagerhat	252	Madaripur	220
Bandarban	200	Magura	208
Barguna	260	Manikganj	185
Barisal	256	Meherpur	185
Bhola	225	Maheshkhali	260
Bogra	198	Moulvibazar	168
Brahmanbaria	180	Munshiganj	184
Chandpur	160	Mymensingh	217
Chapai		Naogaon	175
Nawabganj	130	Narail	222
Chittagong	260	Narayanganj	195
Chuadanga	198	Narsinghdi	190
Comilla	196	Natore	198
Cox's Bazar	260	Netrokona	210
Dahagram	150	Nilphamari	140
Dhaka	210	Noakhali	184
Dinajpur	130	Pabna	202
Faridpur	202	Panchagarh	130
Feni	205	Patuakhali	260
Gaibandha	210	Pirojpur	260
Gazipur	215	Rajbari	188
Gopalganj	242	Rajshahi	155
Habiganj	172	Rangamati	180
Hatiya	260	Rangpur	209
Ishurdi	225	Satkhira	183
Joypurhat	180	Shariatpur	198
Jamalpur	180	Sherpur	200
Jessore	205	Sirajganj	160
Jhalakati	260	Srimangal	160
Jhenaidah	208	St. Martin's Island	260
Khagrachhari	180	Sunamganj	195
Khulna	238	Sylhet	195
Kutubdia	260	Sandwip	260
Kishoreganj	207	Tangail	160
Kurigram	210	Teknaf	260
Kushtia	215	Thakurgaon	130
Lakshmipur	162		

## **b. Exposure Category**

**Exposure A:** Urban and sub-urban areas, industrial areas, wooded areas, hilly or other terrain covering at least 20 percent of the area with obstructions of 6 meters or more in height and extending from the site at least 500 meters or 10 times the height of the structure, whichever is greater.

**Exposure B:** Open terrain with scattered obstruction having heights generally less than 10m extending 800m or more from the site in any full quadrant. This category includes airfields, open park land, sparsely built up outskirts of towns, flat open country and grass land.

**Exposure C:** Flat and unobstructed open terrain, coastal areas and riversides facing large bodies of water, over 1.5 km or more in width. Exposure C extends inland from the shoreline 400m or 10 times the height of structure, whichever greater.

## **2.9 Earthquake Load**

### **Structural System for EQ**

a) **Bearing Wall System:** A structural system having bearing walls or bracing systems without a complete vertical load carrying frame to support gravity loads. Resistance to lateral loads is provided by shear walls or braced frames.

b) **Building Frame System:** A structural system with an essentially complete space frame providing support for gravity loads. Resistance to lateral loads is provided by shear walls or braced frames separately.

c) **Moment Resisting Frame System:** A structural system with an essentially complete space frame providing support for gravity loads. Moment resisting frames also provide resistance to lateral load primarily by flexural action of members, and may be classified as one of the following types:

- i) Special Moment Resisting Frames (SMRF)
- ii) Intermediate Moment Resisting Frames (IMRF)
- iii) Ordinary Moment Resisting Frames (OMRF).

The framing system, IMRF and SMRF shall have special detailing to provide ductile behavior for concrete and steel structures respectively. OMRF need not conform to the ductility requirements.

d) **Dual System:** A structural system having a combination of the following framing systems :

- i) Moment resisting frames (SMRF, IMRF or steel OMRF), and
- ii) Shear walls or braced frames.

The moment resisting frames shall be capable of resisting at least 25% of the applicable total seismic lateral force, even when wind or any other lateral force governs the design.

### **Structural Configurations**

Based on the structural configuration, each structure shall be designated as a regular, or irregular structure as defined below:

- a) **Regular Structures:** Regular structures have no significant physical discontinuities in plan or vertical configuration or in their lateral force resisting systems.
- b) **Irregular Structures:** Irregular structures have significant physical discontinuities in configuration or in their lateral force resisting systems. Irregular structures have either vertical irregularity or plan irregularity or both in their structural configurations.

**Table 2.11: Vertical Irregularities of Structures**

<b>Vertical Irregularity</b>	
<b>Type</b>	<b>Definition</b>
<b>I</b>	<b>Stiffness Irregularity (Soft Storey):</b> A soft storey is one in which the lateral stiffness is less than 70 per cent of that in the storey above or less than 80 per cent of the average stiffness of the three storeys above.
<b>II</b>	<b>Mass Irregularity:</b> Mass irregularity shall be considered to exist where the effective mass of any storey is more than 150 per cent of the effective mass of an adjacent storey. A roof which is lighter than the floor below need not be considered.
<b>III</b>	<b>Vertical Geometric Irregularity:</b> Vertical geometric irregularity shall be considered to exist where horizontal dimension of the lateral force-resisting system in any storey is more than 130 per cent of that in an adjacent storey, one-storey penthouses need not be considered.
<b>IV</b>	<b>In-Plane Discontinuity in Vertical Lateral Force-Resisting Element:</b> An in-plane offset of the lateral load-resisting elements greater than the length of those elements.
<b>V</b>	<b>Discontinuity in Capacity (Weak Storey):</b> A weak storey is one in which the storey strength is less than 80 per cent of that in the storey above. The storey strength is the total strength of all seismic-resisting elements sharing the storey shear for the direction under consideration.

Structures with vertical irregularity Type V as defined in Table 2.11 shall not be over 9.0 metres in height where the weak storey has a calculated strength of less than 65% of the storey above. However, for structures, where a weak storey is capable of resisting a total seismic force of  $0.375R$  times the design force, the above limitation shall not be applied.

**Table 2.12: Plan Irregularities of Structures**

<b>Plan Irregularity</b>	
<b>Type</b>	<b>Definition</b>
<b>I</b>	<b>Torsional Irregularity (to be considered when diaphragms are not flexible):</b> Torsional irregularity shall be considered to exist when the maximum storey drift, computed including accidental torsion, at one end of the structure transverse to an axis is more than 1.2 times the average of the storey drifts of the two ends of the structure.
<b>II</b>	<b>Reentrant Corners:</b> Plan configurations of a structure and its lateral force-resisting system contain reentrant corners, where both projections of the structure beyond a reentrant corner are greater than 1.5 per cent of the plan dimension of the structure in the given direction.
<b>III</b>	<b>Diaphragm Discontinuity:</b> Diaphragms with abrupt discontinuities or variations in stiffness, including those having cutout or open areas greater than 50 per cent of the gross enclosed area of the diaphragm, or changes in effective diaphragm stiffness of more than 50 per cent from one storey to the next.
<b>IV</b>	<b>Out-of-plane Offsets:</b> Discontinuities in a lateral force path, such as out-of-plane offsets of the vertical elements.
<b>V</b>	<b>Nonparallel Systems:</b> The vertical lateral load-resisting elements are not parallel to or symmetric about the major orthogonal axes of the lateral force-resisting system.

### **Selection of Lateral Force Method**

Seismic lateral forces on primary framing systems shall be determined by using either the Equivalent Static Force Method or the Dynamic Response Method complying with the restrictions given below :

- a) The Equivalent Static Force Method may be used for the following structures:
  - i) All structures, regular or irregular, in Seismic Zone 1 and in Structure Importance Category IV in Seismic Zone 2, except case b(iv) below.
  - ii) Regular structures under 75 metres in height with lateral force resistance provided by structural systems except case b(iv) below.
  - iii) Irregular structures not more than 20 metres in height.



iv) A tower like building or structure having a flexible upper portion supported on a rigid lower portion where:

- 1) both portions of the structure considered separately can be classified as regular structures,
- 2) the average storey stiffness of the lower portion is at least ten times the average storey stiffness of the upper portion, and
- 3) the period of the entire structure is not greater than 1.1 times the period of the upper portion considered as a separate structure fixed at the base.

b) The Dynamic Response Method may be used for all classes of structure, but shall be used for structures of the following types:

- i) Structures 75 metres or more in height except as permitted by case a(i) above.
- ii) Structures having a stiffness, weight or geometric vertical irregularity of Type I, II, or III or structures having irregular features.
- iii) Structures over 20 metres in height in Seismic Zone 3 not having the same structural system throughout their height.
- iv) Structures, regular or irregular, located on Soil Profile Type S4, which have a period greater than 0.7 second.

#### **Equivalent Static Force Method:**

This method may be used for calculation of seismic lateral forces for all structures.

**Design Base Shear:** The total design base shear in a given direction shall be determined from the following relation :

$$V = \frac{ZIC}{R} W$$

where,

$Z$  = Seismic zone coefficient given in Table 2.13.

$I$  = Structure importance coefficient given in Table 2.14.

$R$  = Response modification coefficient for structural systems given in Table 2.16.

$W$  = The total seismic dead load

$C$  = Numerical coefficient given by the relation:

$$= \frac{1.25 S}{T^{2/3}}$$

$S$  = Site coefficient for soil characteristics as provided in Table 2.17.

$T$  = Fundamental period of vibration in seconds, of the structure for the direction under consideration.

**Table 2.13:**

**Seismic Zone Coefficients,  $Z$**

Seismic Zone	Zone Coefficient
1	0.075
2	0.150
3	0.250

**Table 2.14:**

**Structure Importance Coefficients  $I, I'$**

Structure Importance Category	Structure Importance Coefficient	
	$I$	$I'$
I Essential facilities	1.25	1.50
II Hazardous facilities	1.25	1.50
III Special occupancy structures	1.00	1.00
IV Standard occupancy structures	1.00	1.00
V Low-risk Structures	1.00	1.00

The value of  $C$  need not exceed 2.75 and this value may be used for any structure without regard to soil type or structure period. Except for those requirements where Code prescribed forces are scaled up by  $0.375R$ , the minimum value of the ratio  $C/R$  shall be 0.075.

Definition of different facilities as mentioned in Table 2.14 is summarized in Table 2.15.

**Structure Period:** For all buildings the value of  $T$  may be approximated by the following formula:

$$T = C_t (h_n)^{3/4}$$

where,  $C_t = 0.083$  for steel moment resisting frames

= 0.073 for reinforced concrete moment resisting frames, and eccentric braced steel frames

= 0.049 for all other structural systems

$h_n =$  Height in metres above the base to level  $n$ .

**Table 2.15: Structure Importance Categories**

Structure Importance Category	Occupancy Type or Functions of Structure	
	General	Particular
I	Essential Facilities	<ol style="list-style-type: none"> <li>1. Hospital and other medical facilities having surgery and emergency treatment area.</li> <li>2. Fire and police stations.</li> <li>3. Tanks or other structures containing, housing or supporting water or other fire-suppression materials or equipment required for the protection of essential or hazardous facilities, or special occupancy structures.</li> <li>4. Emergency vehicle shelters and garages.</li> <li>5. Structures and equipment in emergency-preparedness centres, including cyclone and flood shelters.</li> <li>6. Standby power-generating equipment for essential facilities.</li> <li>7. Structures and equipment in government communication centres and other facilities required for emergency response.</li> </ol>
II	Hazardous Facilities	Structures housing, supporting or containing sufficient quantities of toxic or explosive substances to be dangerous to the safety of the general public if released.
III	Special Occupancy Structures	<ol style="list-style-type: none"> <li>1. Covered structures whose primary occupancy is public assembly with capacity &gt; 300 persons.</li> <li>2. Buildings for schools through secondary or day-care centre with capacity &gt; 250 students.</li> <li>3. Buildings for colleges or adult education schools with capacity &gt; 500 students.</li> <li>4. Medical facilities with 50 or more resident incapacitated patients not included above.</li> <li>5. Jails and detention facilities.</li> <li>6. All structures with occupancy &gt; 5,000 persons.</li> <li>7. Structures and equipment in power-generating stations and other public utility facilities not included above, and required for continued operation.</li> </ol>
IV	Standard Occupancy Structures	All structures having occupancies or functions not listed above.
V	Low Risk Structures	Buildings and Structures that exhibit a low risk to human life and property in the event of failure, such as agricultural buildings, minor storage facilities, temporary facilities, construction facilities, and boundary walls.

**Table 2.16: Response Modification Coefficient for Structural Systems, *R***

<b>Basic Structural System<sup>(1)</sup></b>	<b>Description of Lateral Force Resisting System</b>	<b><i>R</i></b>
a. Bearing Wall System	1. Light framed walls with shear panels	
	i) Plywood walls for structures, 3 storeys or less	8
	ii) All other light framed walls	6
	2. Shear walls	
	i) Concrete	6
	ii) Masonry	6
	3. Light steel framed bearing walls with tension only bracing	4
	4. Braced frames where bracing carries gravity loads	
	i) Steel	6
ii) Concrete <sup>(2)</sup>	4	
iii) Heavy timber	4	
b. Building Frame System	1. Steel eccentric braced frame (EBF)	10
	2. Light framed walls with shear panels	
	i) Plywood walls for structures 3-storeys or less	9
	ii) All other light framed walls	7
	3. Shear walls	
	i) Concrete	8
	ii) Masonry	8
	4. Concentric braced frames (CBF)	
	i) Steel	8
ii) Concrete <sup>(2)</sup>	8	
iii) Heavy timber	8	
c. Moment Resisting Frame System	1. Special moment resisting frames (SMRF)	
	i) Steel	12
	ii) Concrete	12
	2. Intermediate moment resisting frames (IMRF), concrete <sup>(3)</sup>	8
	3. Ordinary moment resisting frames (OMRF)	
	i) Steel	6
ii) Concrete <sup>(4)</sup>	5	
d. Dual System	1. Shear walls	
	i) Concrete with steel or concrete SMRF	12
	ii) Concrete with steel OMRF	6
	iii) Concrete with concrete IMRF <sup>(3)</sup>	9
	iv) Masonry with steel or concrete SMRF	8
	v) Masonry with steel OMRF	6
	vi) Masonry with concrete IMRF <sup>(2)</sup>	7
	2. Steel EBF	
	i) With steel SMRF	12
	ii) With steel OMRF	6
	3. Concentric braced frame (CBF)	
	i) Steel with steel SMRF	10
	ii) Steel with steel OMRF	6
iii) Concrete with concrete SMRF <sup>(2)</sup>	9	
iv) Concrete with concrete IMRF <sup>(2)</sup>	6	
<b>Notes :</b> (1) Basic Structural Systems.		
(2) Prohibited in Seismic Zone 3.		
(3) Prohibited in Seismic Zone 3		
(4) Prohibited in Seismic Zones 2 and 3.		

**Table 2.17: Site Coefficient,  $S$  for Seismic Lateral Forces (1)**

Site Soil Characteristics		Coefficient, $S$
Type	Description	
S <sub>1</sub>	A soil profile with either : a) A rock-like material characterized by a shear-wave velocity greater than 762 m/s or by other suitable means of classification, or b) Stiff or dense soil condition where the soil depth is less than 61 metres	1.0
S <sub>2</sub>	A soil profile with dense or stiff soil conditions, where the soil depth exceeds 61 metres	1.2
S <sub>3</sub>	A soil profile 21 metres or more in depth and containing more than 6 metres of soft to medium stiff clay but not more than 12 metres of soft clay	1.5
S <sub>4</sub>	A soil profile containing more than 12 metres of soft clay characterized by a shear wave velocity less than 152 m/s	2.0
<b>Note :</b> (1) The site coefficient shall be established from properly substantiated geotechnical data. In locations where the soil properties are not known in sufficient detail to determine the soil profile type, soil profile S <sub>3</sub> shall be used. Soil profile S <sub>4</sub> need not be assumed unless the building official determines that soil profile S <sub>4</sub> may be present at the site, or in the event that soil profile S <sub>4</sub> is established by geotechnical data.		

**Vertical Distribution of Lateral Forces:** In the absence of a more rigorous procedure, the total lateral force, which is the base shear  $V$ , shall be distributed along the height of the structure:

$$V = F_t + \sum_{i=1}^n F_i$$

where,  $F_i$  = Lateral force applied at storey level  $-i$  and

$F_t$  = Concentrated lateral force considered at the top of the building in addition to the force  $F_n$ .

The concentrated force,  $F_t$  acting at the top of the building shall be determined as follows:

$$F_t = 0.07 TV \leq 0.25 V \quad \text{when } T > 0.7 \text{ second}$$

$$F_t = 0.0 \quad \text{when } T \leq 0.7 \text{ second}$$

The remaining portion of the base shear ( $V - F_t$ ), shall be distributed over the height of the building, including level- $n$ , according to the relation:

$$F_x = \frac{(V - F_t)w_x h_x}{\sum_{i=1}^n w_i h_i}$$

At each storey level- $x$ , the force  $F_x$  shall be applied over the area of the building in proportion to the mass distribution at that level.

### Drift of the Storey

Storey drift is the displacement of one level relative to the level above or below due to the design lateral forces. Calculated storey drift shall include both translational and torsional deflections and conform to the following requirements:

- a) Storey drift,  $\Delta$ , shall be limited as follows:
  - i)  $\Delta \leq 0.04h/R \leq 0.005h$  for  $T < 0.7$  second.
  - ii)  $\Delta \leq 0.03h/R \leq 0.004h$  for  $T \geq 0.7$  second.
  - iii)  $\Delta \leq 0.0025h$  for unreinforced masonry structures.

where,  $h$  = height of the building or structure.

The period  $T$  used in this calculation shall be the same as that used for determining the base shear. The limits involving  $R$  in (i) and (ii) above shall be applicable only when earthquake forces are present.

- b) The drift limits set out in (a) above may be exceeded where it can be demonstrated that greater drift can be tolerated by both structural and nonstructural elements without affecting life safety.

### EQ Magnitude

According to the depth of focus, tectonic earthquake is classified as:

*Shallow*: depth of focus is "less than 60 km.

*Intermediate*: depth of focus between 60 to 70' km.

*Deep*: depth of focus above 70 km.

**Scale:** The scale of earthquake intensities was conveniently classified into 12 categories, till 1935, when C.F. Richter devised a scale indicating numerical 15; magnitude of the intensity of earthquake, 10 is the highest on this scale. The greater the number more is the damaging power.

The intensity of earthquake in terms of Richter scale is expressed as:

- 1) *Instrumental*: detected by seismograph, magnitude 1-3;
- 2) *Feeble*: noticed only by sensitive people
- 3) *Slight*: is like vibration of passing lorry, felt on upper floors, magnitude'. 3.5 to 4.2;
- 4) *Moderate*: felt while walking, magnitude 4.3;
- 5) *Rather Strong*: most sleeper awakened, magnitude 4.8;
- 6) *Strong*: trees sway, suspended objects swing, falling loose, objects, magnitude 4.9- 5.4;
- 7) *Very Strong*: walls crack, plaster falls, magnitude 5.5-6;
- 8) *Destructive*: chimneys fall; buildings damaged, magnitude 6.8;
- 9) *Ruinous*: houses collapse, ground cracks, pipes break open, magnitude 6.9;
- 10) *Disastrous*: ground cracks badly budes. Destroyed, rail lines bent, magnitude 7-7.3;
- 11) *Very Disastrous*: few buildings remain standing; bridges destroyed, great landslide and flood, magnitude 7.4-8.7;
- 12) *Catastrophic*: total destruction. Objects thrown into air, ground rises and falls in waves, magnitude 8.2 and above.

There are three zones namely zone I, being most active, zone II, less active and zone III, being the minimum possible intensity of earthquake. Seismic probable magnitudes are:

Zone	(Richter scale)
I	>7.0
II	6.5-7.0
III	6.0-6.5

The design of buildings against earthquake should obviously be done in Zone I. However, for low height buildings additional provision of 33% Reinforcement may be provided. For high rise buildings proper technical Design should be done by qualified Civil Engineers.

## CHAPTER 3

# METHODOLOGY OF THE STUDY

### 3.1 General

This chapter gives the outlines of the procedures that were followed to complete this study.

### 3.2 Study procedures

#### *Step-I: Selection of a structural system*

A 18-storied high-rise structure having edge supported floor system with shear wall (frame structure) had been considered. The whole structure is a residential building. Description of the whole structure is provided in *Chapter 4*.

#### *Step-II: Selection of the material properties & loadings*

As per discussions made in *Chapter 2* and based on design code/specifications of *ACI/BNBC*, material properties (compressive strength of concrete, yield stress of steel, unit weight of concrete, soil, brick etc.) and loadings (standard live load, floor finish, dead load etc.) were selected. Wind and earthquake loads were also considered.

#### *Step-III: Design of the structure*

The structure was analyzed and designed by ETABS 2016 software and followed by ultimate strength design (*USD*) with high rise design concept. *Chapters 4* provides detailed structural design of the different components of the structure.

#### *Step-IV: Conclusions & Recommendations*

Based on study, few concluding remarks were drawn. To carry out further study on this topic, recommendations were proposed in the *Chapter 5*.



## CHAPTER 4

### DETAILS OF THE PROPOSED BUILDING

#### 4.1 Introduction

This chapter assigned for this group completed the planning, modelling, analysis, design and detailing of the structural parts of the building for the proposed residential building.

#### 4.2 Details of Loads and Material Properties of

The whole study was carried out based on few considerations and specifications which are summarized in Table 4.1 below.

**Table 4.1: Summary of the design considerations and specification of the study**

Items	Description
<i>Design code</i>	<ul style="list-style-type: none"> <li>• American Concrete Institute (ACI) Building design code, 2014.</li> <li>• Bangladesh National Building Code (BNBC), 1993.</li> </ul>
<i>Building components</i>	<ul style="list-style-type: none"> <li>• Column type = Tied</li> <li>• Footing type = Pile foundation</li> <li>• Thickness of all partition walls = 5.0 inch.</li> <li>• Thickness of Slab = 5.0 inch.</li> </ul>
<i>Material properties</i>	<ul style="list-style-type: none"> <li>• Yield strength of reinforcing bars, <math>f_y = 60,000 \text{ psi}</math>.</li> <li>• Concrete compressive strength, <math>f_c' = 4,000 \text{ psi}</math></li> <li>• Normal density concrete, unit weight = 150 pcf.</li> <li>• Unit weight of brick = 120 pcf.</li> <li>• Unit weight of water = 62.5 pcf.</li> </ul>

#### 4.2.1 Load Calculation

##### (a) Dead loads:

Self-weight of slab =  $(5/12) \times 150 = 62.5 \text{ psf}$ .

Floor finish = 30 psf.

5" Partition wall Load calculation = 50 psf.

**(b) Other dead loads:**

Floor finish for parking floor space	= 10 <i>psf</i> .
Floor finish for water tank	= 10 <i>psf</i> .
Floor finish for stair	= 30 <i>psf</i> .

**(c) Live loads:**

Live load for all stair	= 100 <i>psf</i> .
Live load for water tank slab	= 10 <i>psf</i> .
Water pressure for water tank	= 406.25 <i>psf</i> .
Live load for floor	= 40 <i>psf</i> .

**(d) Seismic load:**

Height of building	= 182' = 56.40 <i>m</i>
Seismic zone Coefficient (Dhaka zone)	= 0.15
Response modification coefficient, R [Dual System, Shear wall (IMRF)]	= 9.00
Importance Coefficient for residential building (standard occupancy), <i>I</i>	= 1.00
Story range	= Base to roof.

**(e) Wind load:**

Length of building	= 95ft 0 inch.
Width of building	= 66 ft 8 inch.
Exposure Condition	= B
Wind Pressure in Dhaka city, $V_b$	= 131 <i>mph</i>
Importance Coefficient, <i>I</i>	= 1.00
Story range	= Ground Floor to Parapet.

Wind load and Earthquake load were auto-calculated by ETABS-2016 according to UBC-94 which is most acquainted with BNBC-93 code.

**4.3 Floor Plan details**

- Height of building : 185 *ft*.
- Length of building : 95ft 0 *inch*.
- Width of building : 66 ft 8 *inch*.
- Total floors : 18 nos.
- Types of floors : Basement & Ground Floor as Parking  
1<sup>st</sup> – 17<sup>th</sup> Story as Residential Building.

The 3D view from 3D Max and structural model view from ETABS of the whole structure are shown in Figures 4.1 and 4.2.



Figure 4.1a: 3D view of the Building



Figure 4.1b: Back side View of Building



Figure 4.1c: Right side View of Building



Figure 4.1d: Left side View of Building

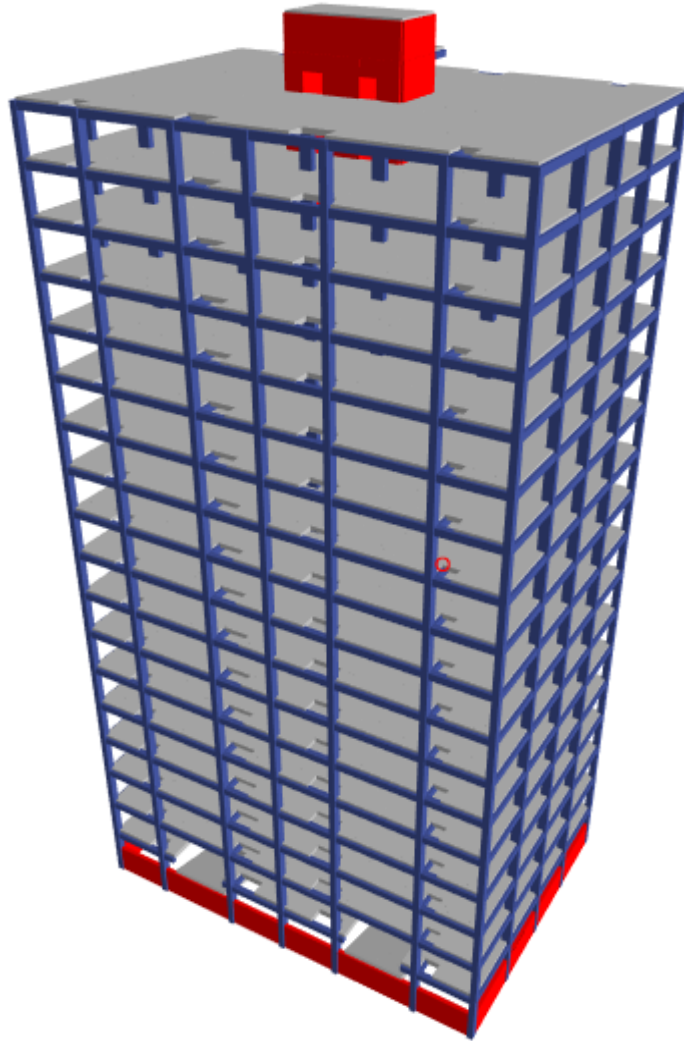

Figure 4.2: 3D Structural View (frame) as per ETABS

**Description of the different floors:****Basement:**

- 7' below from road level and connected with other floors by one Stair & two passengers' lifts.
- Total floor area is =  $6333.33 \text{ ft}^2$ .
- Total floor height 12'-0".
- Used for car parking
- Underground water reservoir facilities
- This floor has Wash room facilities, Security & Driver Rest Room, Power Generator room.

**Ground Floor:**

- 5' above from road level and connected with other floors by one Stair & two passengers' lifts.
- Total floor area is =  $6333.33 \text{ ft}^2$ .
- Total floor height 10'-0".
- This floor has Car parking.

**1<sup>st</sup> ~ 17<sup>th</sup> Floors:**

- Floor height 10'-0".
- Total floor area is =  $6333.33 \text{ ft}^2$ .
- Connected with other floors by one stairs & two passengers' lifts.

**Roof Top:**

- Connected with roof tops by one Stair.
- Contains one water tanks.

Details of Basement, Ground Floor, 1<sup>st</sup> to 17<sup>th</sup> Floors and Roof top are shown in Figures 4.3~4.6.



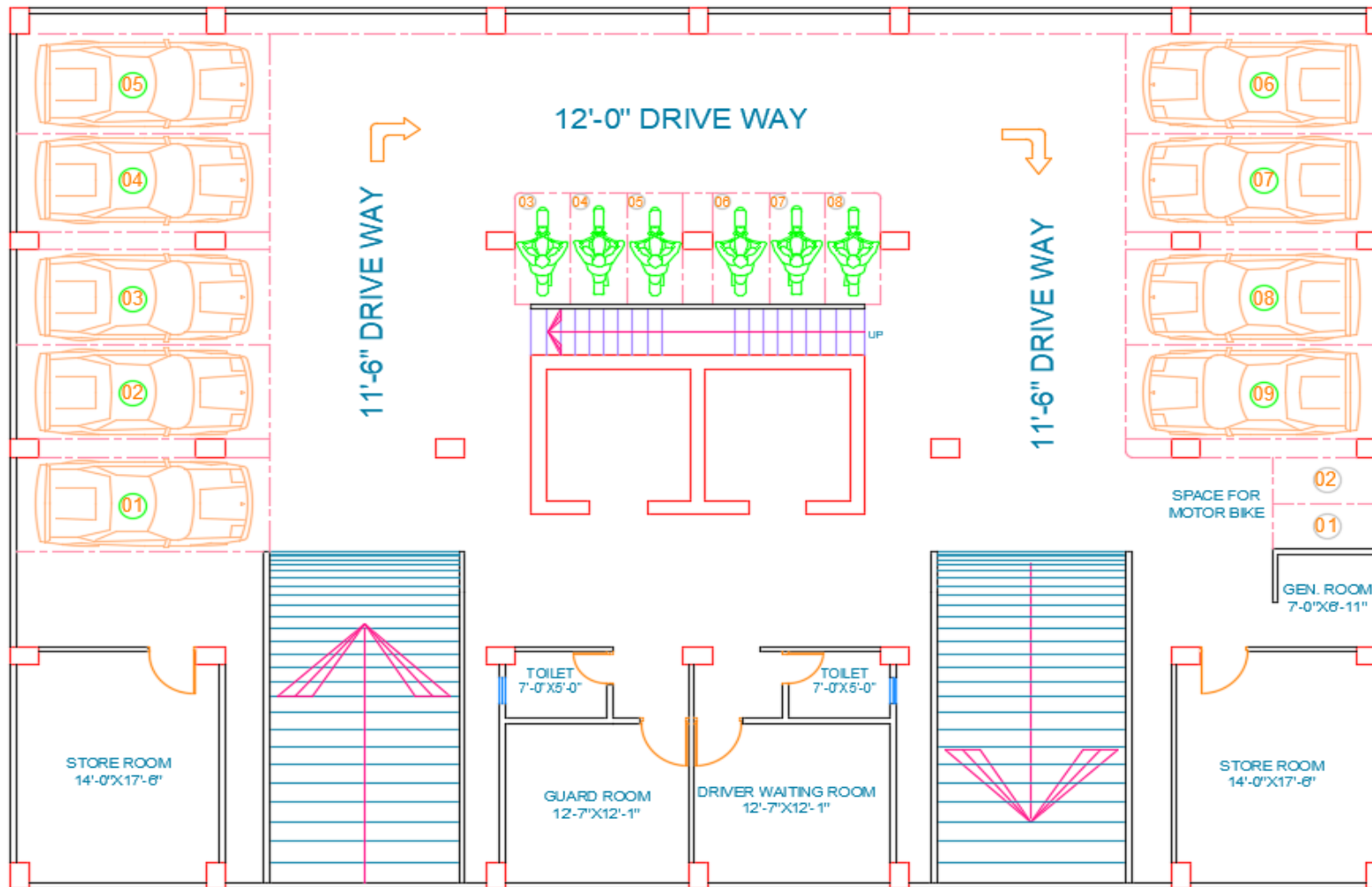

Figure 4.3: Plan view of Basement.

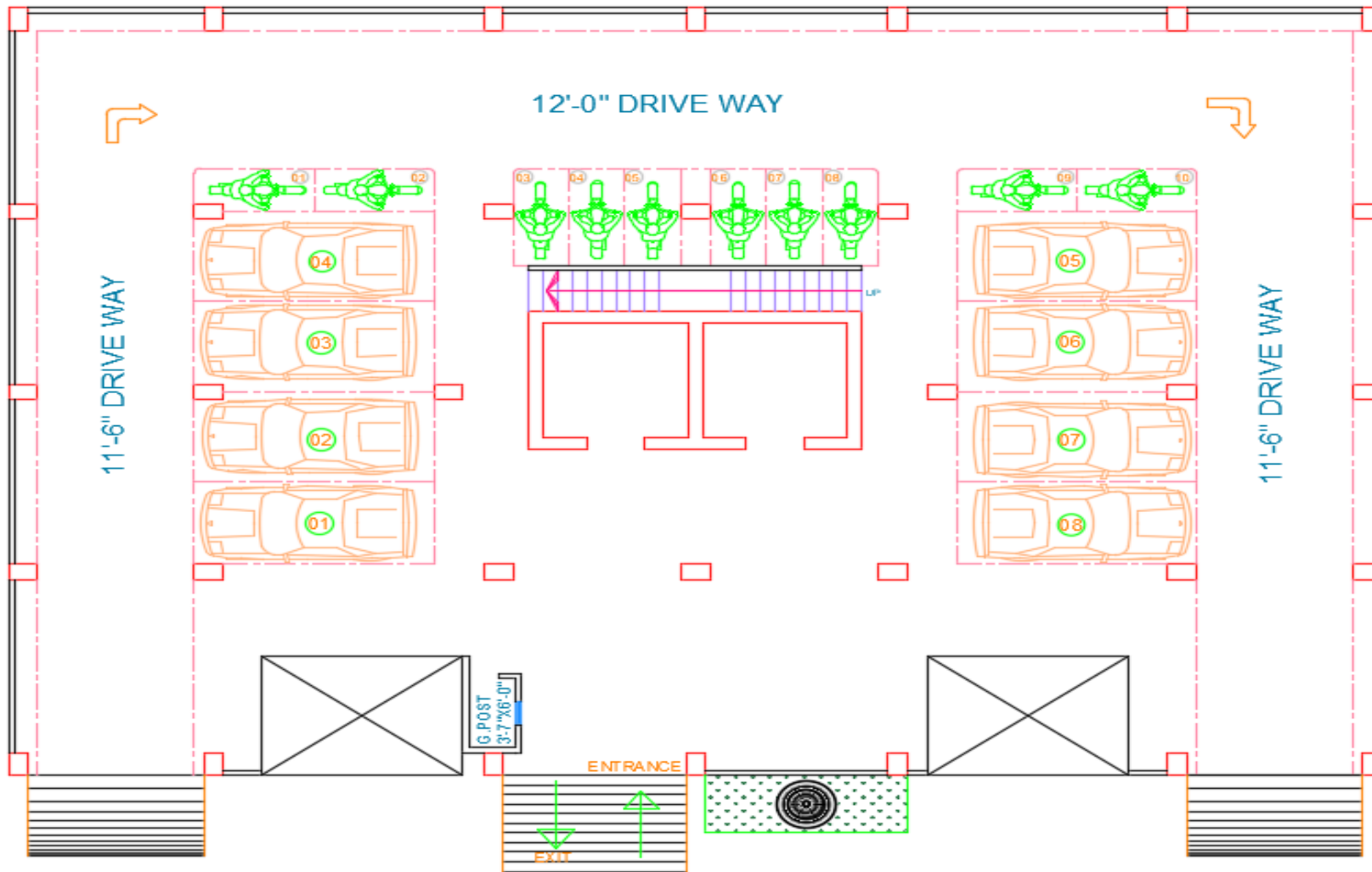

Figure 4.4: Plan view of Ground Floor.

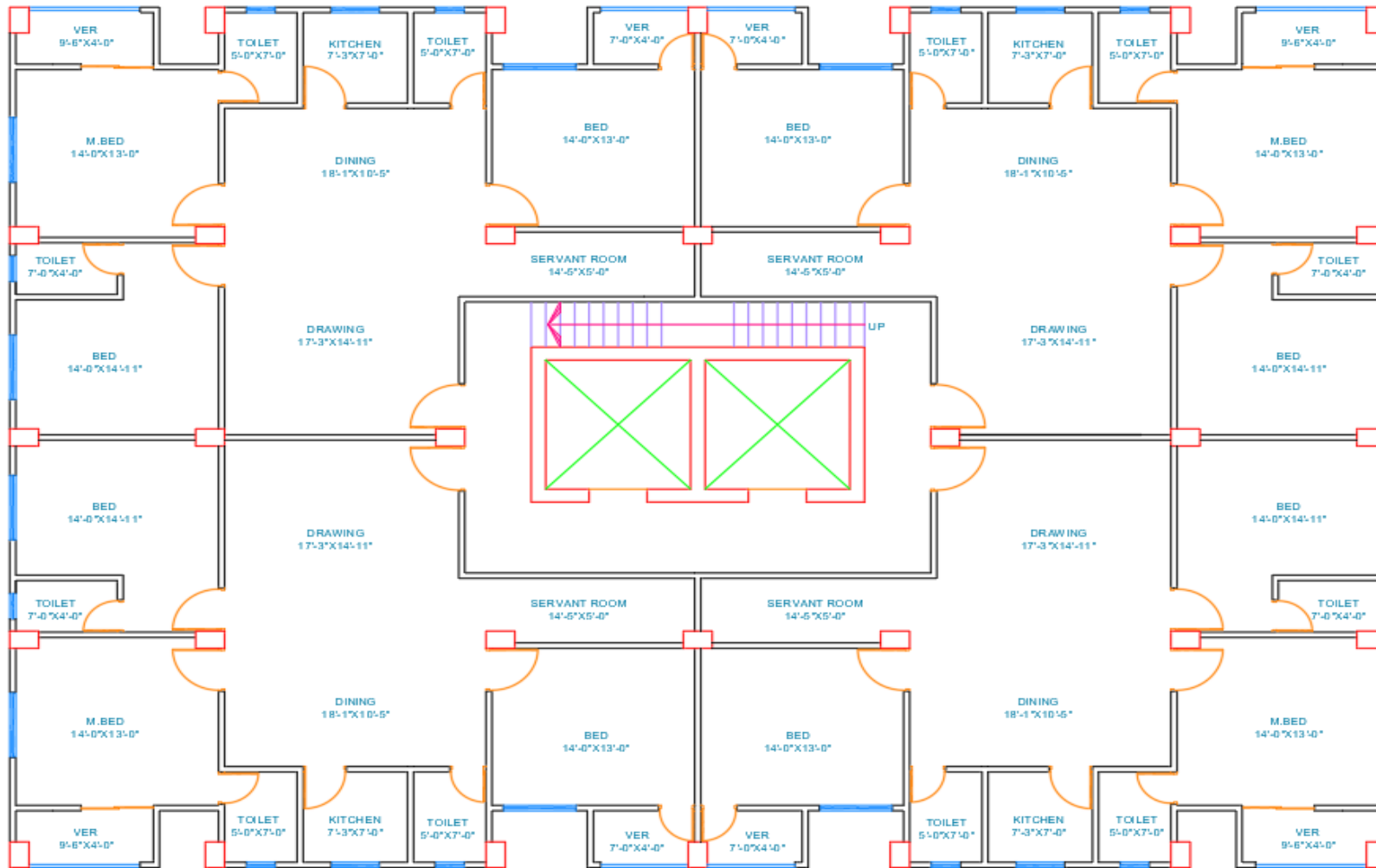

Figure 4.5: Plan view of 1<sup>st</sup> to 17<sup>th</sup> Floor

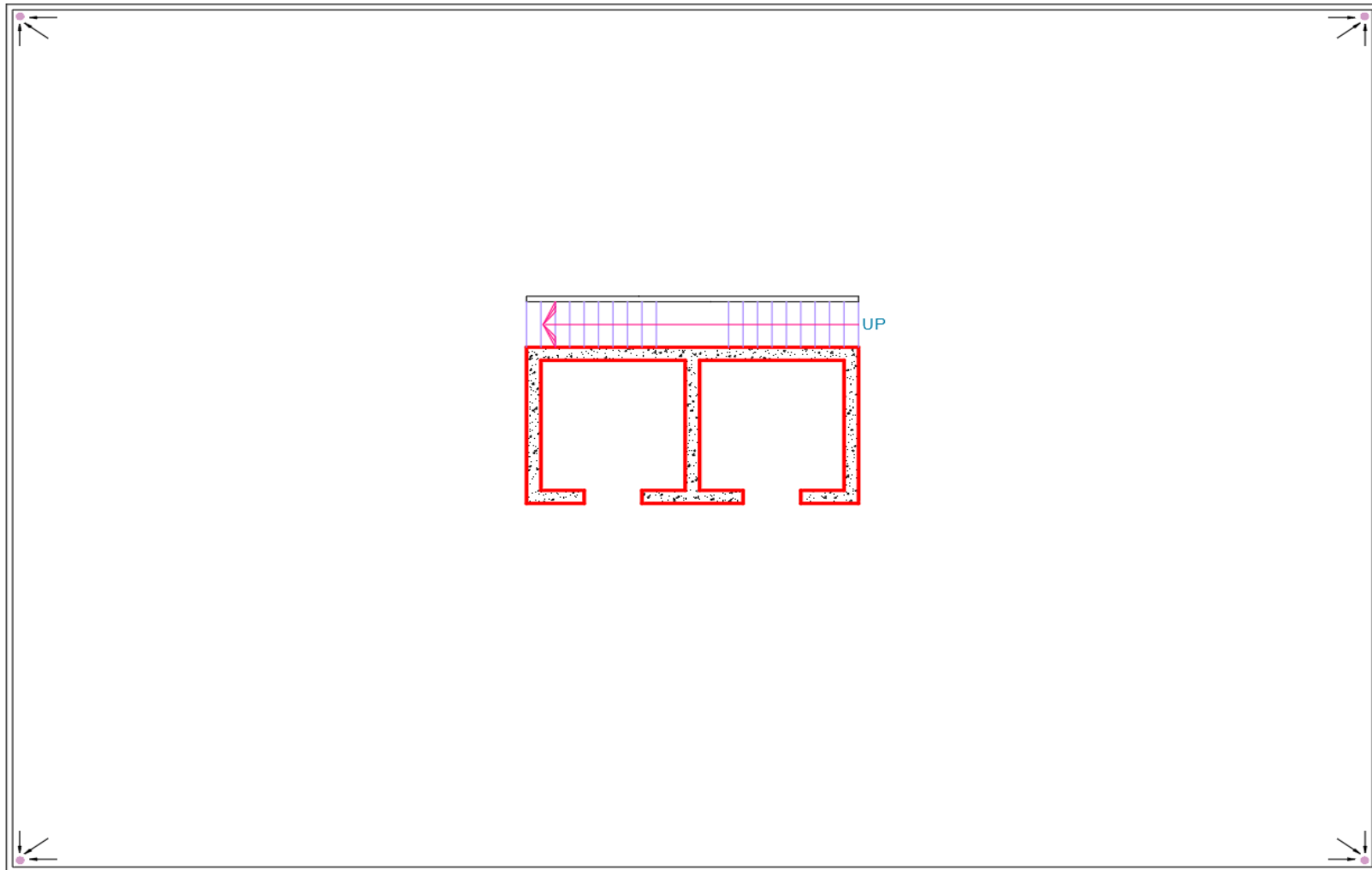

Figure 4.6: Plan view of Roof Top

## 4.4 Structural details

This part includes the portions of results of analysis, design and detailing of Slab, Beam, Column, Stair, Lift core, Water tank etc.

### Detailing of Slab

All slab panels are analyzed, designed and detailed by ETABS and SAFE software. Detailing of different slab panels shown in Figure 4.7.

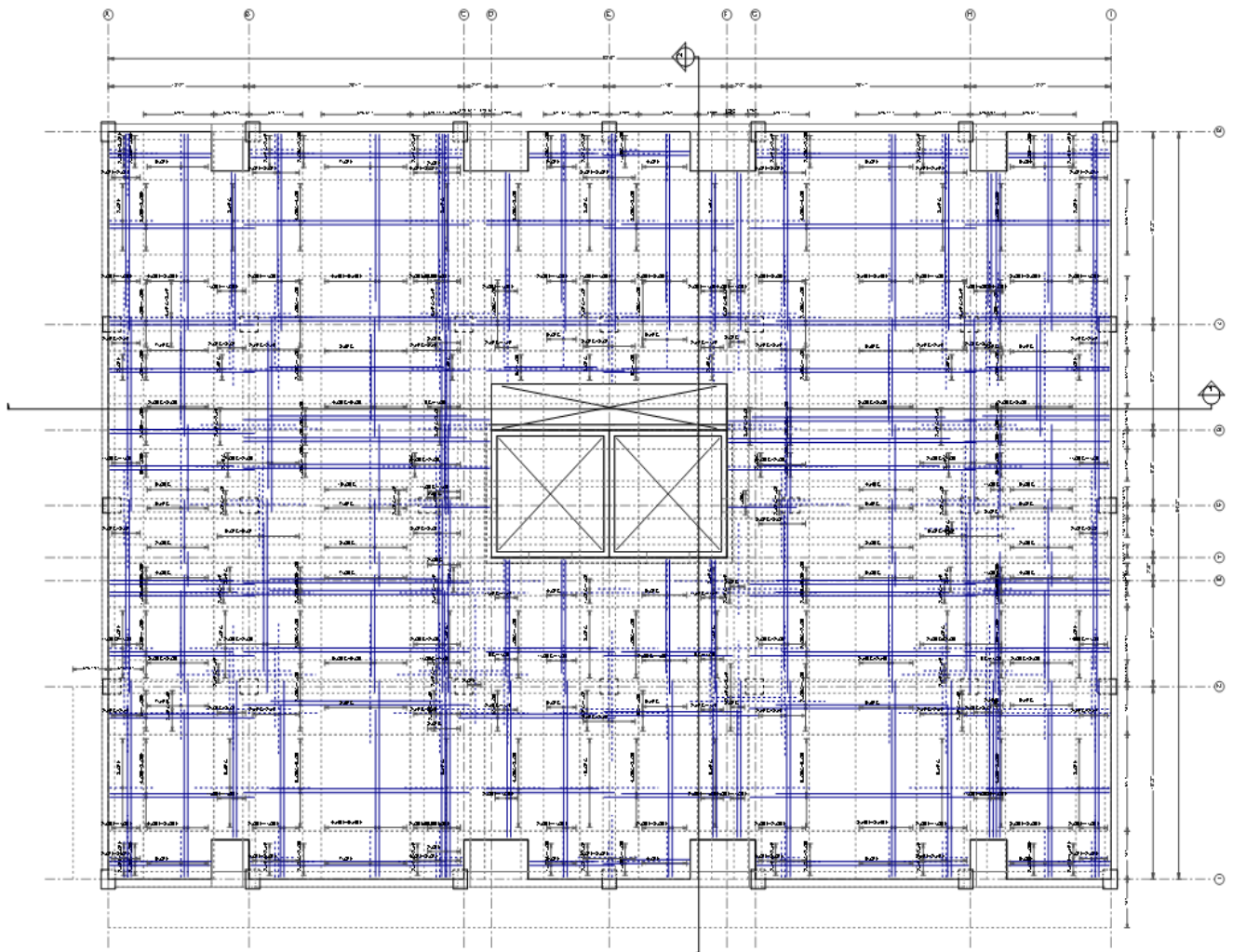

Figure 4.7a: Slab detailing of 16<sup>th</sup> Floor

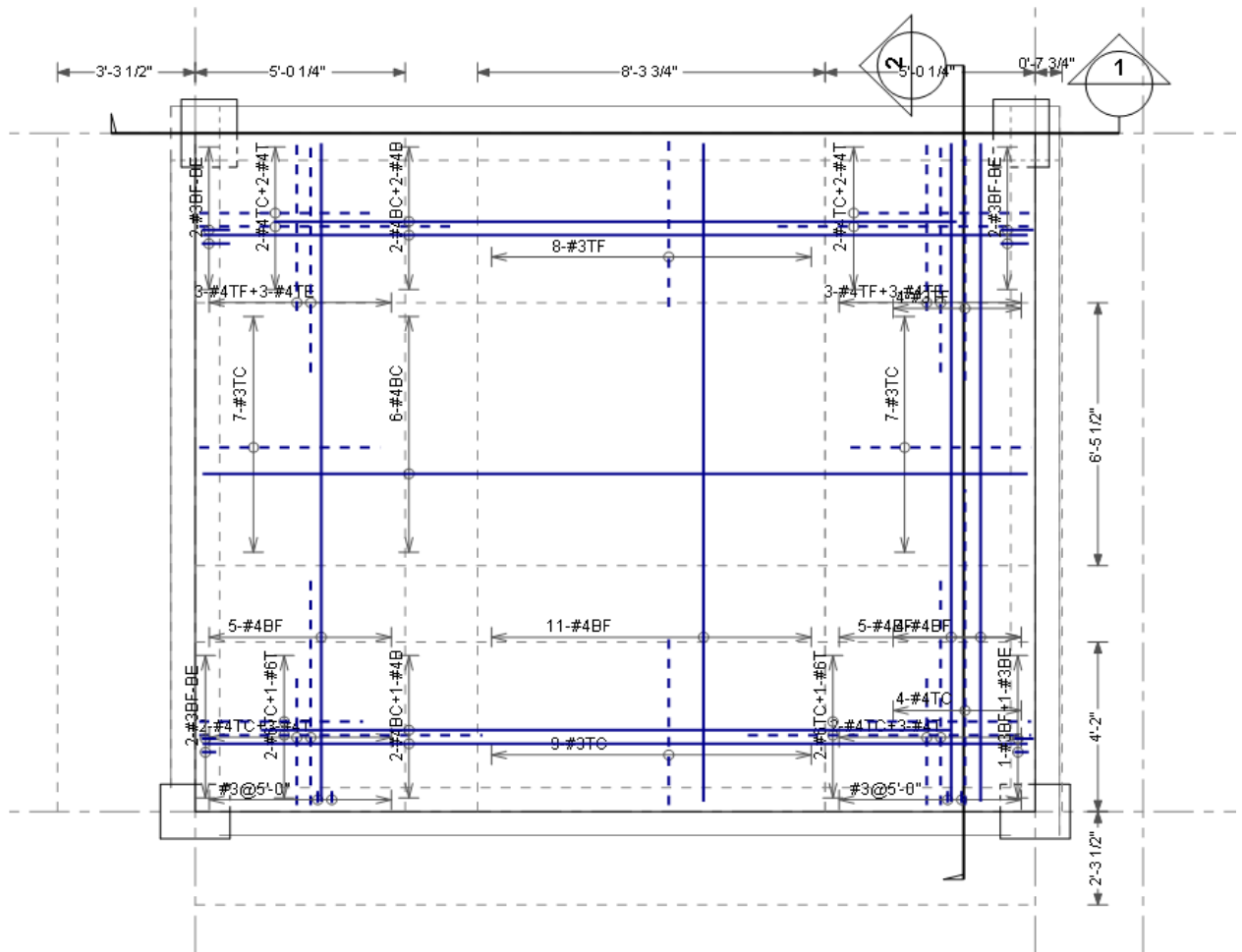

Figure 4.7b: Slab detailing of 16<sup>th</sup> Floor (Partial)

### **Detailing of Beam**

This gives details of floor beam design for lateral loadings. There are several floor beams in this structure. All beams are analyzed by ETABS software. For space limitations, design of grid 7, frame G-H of 6<sup>th</sup> floor is presented here.

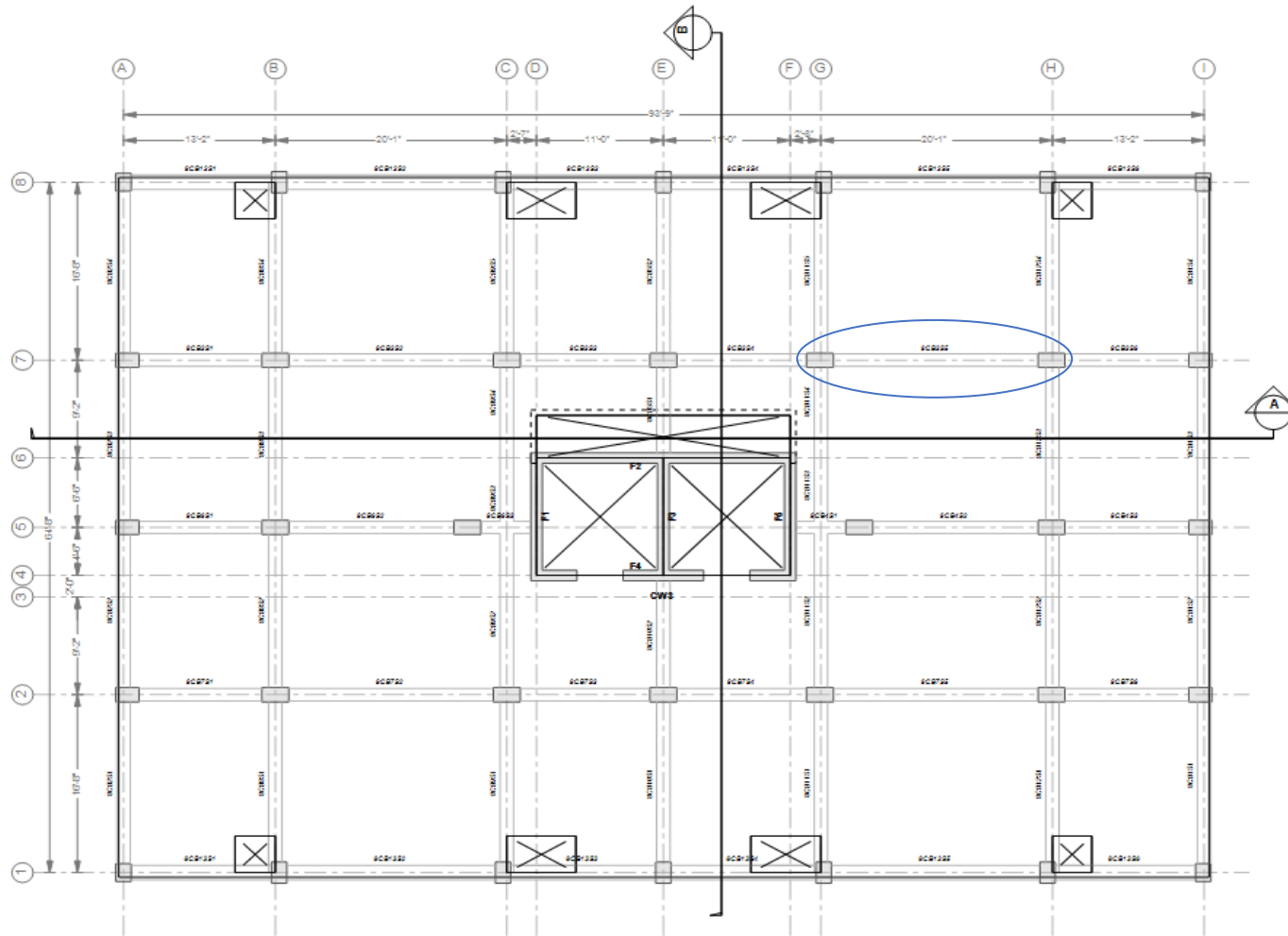

Figure 4.8: Floor beam layout of 6<sup>th</sup> floor

### 1. Dimension of the beam:

Assume the Size of Beam =  $b \times h = 14'' \times 20''$

### 2. Longitudinal reinforcement of beam:

Moment, Shear and Steel area of the Beam and details from ETABS analysis are given below by table.

Table 4.2a: Details of Longitudinal Reinforcement (Bottom)

Beam Portion		End - I	Middle	End - J
<b>Bottom</b>	Moment, $M_u$	+49.82 K-ft	+72.35 K-ft	+39.37 K-ft
	As (Required)	$0.82 \text{ in}^2$	$0.98 \text{ in}^2$	$0.67 \text{ in}^2$
		Use 2 $\phi$ 20mm Bar	Use 2 $\phi$ 20mm Bar +1 $\phi$ 16mm Bar	Use 2 $\phi$ 20mm Bar
	As (Provided)	$0.88 \text{ in}^2$	$1.19 \text{ in}^2$	$0.88 \text{ in}^2$

Table 4.2b: Details of Longitudinal Reinforcement (Top)

Beam Portion		End - I	Middle	End - J
<b>Top</b>	Moment, $M_u$	-152.93 K-ft	-30.59 K-ft	-136.58 K-ft
	As (Required)	$2.11 \text{ in}^2$	$0.53 \text{ in}^2$	$1.88 \text{ in}^2$
		Use 2 $\phi$ 20mm Bar +3 $\phi$ 20mm Bar	Use 2 $\phi$ 20mm Bar	Use 2 $\phi$ 20mm Bar +3 $\phi$ 20mm Bar
	As (Provided)	$2.2 \text{ in}^2$	$0.88 \text{ in}^2$	$2.2 \text{ in}^2$

### 3. Transverse/Shear Reinforcement:

There will be 3 types of reinforcement for share.

Table 4.3: Details of Shear Reinforcement

Beam Portion	End - I	Middle	End - J
Shear Force, $V_u$	38.66 Kip	1.23 Kip	34.37 Kip
Shear Steel	$0.24 \text{ in}^2/\text{ft}$	$0.14 \text{ in}^2/\text{ft}$	$0.17 \text{ in}^2/\text{ft}$



**(a) Seismic Stirrup:**

Use  $\phi 12\text{mm}$  as Seismic Stirrups.

- **Spacing**

$$S_{max} = \frac{d}{4} = \frac{17.5}{4} = 4.375" \equiv 4" \text{ c/c}$$

$$S_{max} = 8 \times \text{minimum dia. of main bar} = 8 \times \frac{6}{8} = 6" \text{ c/c}$$

$$S_{max} = 24 \times \text{hoops bar dia.} = 24 \times \frac{4}{8} = 15" \text{ c/c}$$

$\therefore S_{max} = 4" \text{ c/c}$  is selected.

Here,  $\frac{A_v}{s} = 0.24$

$$A_v = 0.24 \times 4 = 0.96 \text{ in}^2$$

For 2-leg 12mm stirrup and  $A_v = 0.20 \times 2 = 0.40 \text{ in}^2$

So cross tie is required.

So, excess  $A_v = 0.96 - 0.40 = 0.56 \text{ in}^2$

3 $\phi 12\text{mm}$  cross ties are required.

A closed hoop with seismic hook plus 3 $\phi 12\text{mm}$  cross ties will be provided. The first one is placed 2" from each face of column. The others are placed @ 4" c/c within  $2h = 2 \times 20 = 40"$  from both faces of column.

**(b) Splicing Stirrups:**

- ❖ **Splice Length**

For top bars, class A and for bottom bars, class B lap splices will be provided.

Total splice length for top bars =  $l_d$

Total splice length for bottom bars =  $1.3 l_d$

Here,

- For  $\phi 20\text{mm}$  bar

$$l_d \geq \frac{0.04 \times A_b \times f_y}{\sqrt{f'_c}} = \frac{0.04 \times 0.44 \times 60000}{\sqrt{4000}} = 16.70"$$

$$l_d \geq 0.0003 d_b f_y = 0.0003 \times .75 \times 60000 = 13.5''$$

$$l_d = 12''$$

Selected,  $l_d = 16.70'' \equiv 17''$

Splice length for  $\phi 20\text{mm}$  (bottom) bars =  $1.3 \times 17'' = 22.10'' \equiv 23''$

Splice length for  $\phi 20$  (top) bars =  $20''$

#### ❖ Splice Location

- (i) Lap splices of the bars should not be placed within the beam-column joint and within a distance  $2h = 2 \times 20 = 40''$  from both support faces.
- (ii) Lap splices of bottom bars should be made immediately beyond the  $2h$  distance.
- (iii) Lap splices of top bars should be placed at or near mid span.

#### ❖ Spacing

Total splice length of top & bottom bars should be confined by close hoops with seismic hooks.

$$\text{Spacing, } S = d/4 = 17.5/4 = 4.38'' \equiv 4'' \text{ c/c}$$

or  $S = 4.0'' \text{ c/c}$

So, provide  $\phi 16\text{mm}$  closed hoops with seismic hook @  $4'' \text{ c/c}$  along the total splice length.

#### (c) Regular Stirrups:

Except confinement zone & lap splices length for top & bottom bars, the regular stirrup  $\phi 12\text{mm}$  will be provided spacing @  $\frac{d}{2} = \frac{17.5}{2} = 8.75'' \equiv 8.5'' \text{ c/c}$

Selected spacing  $8.5'' \text{ c/c}$  for regular stirrup.

Other beams of the frame were designed as per similar procedure Details of reinforcement arrangement is shown in Figure 4.9.

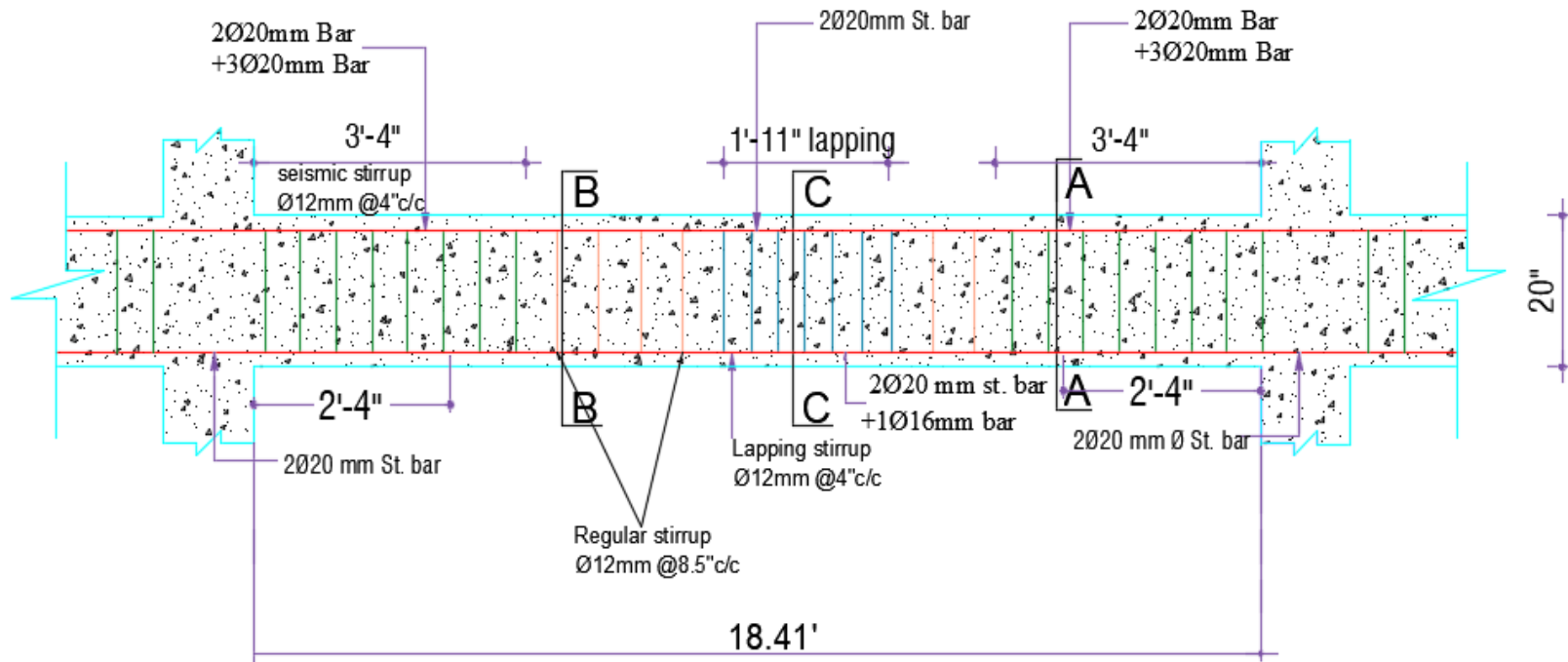

Figure 4.9a: Longitudinal Section Reinforcement of Beam

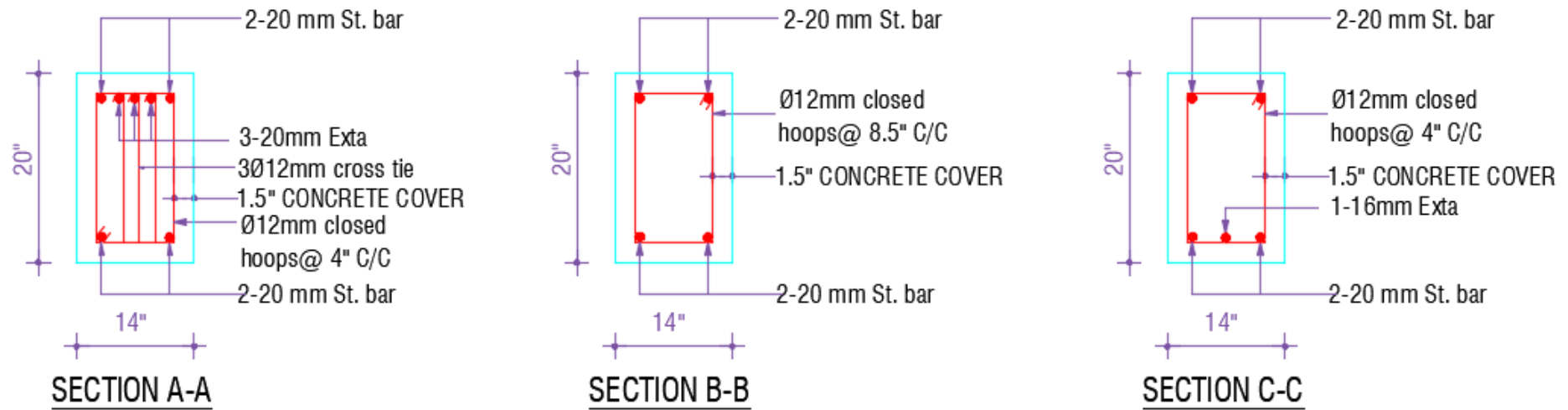

Figure 4.9b: Cross Section at three locations of Beam

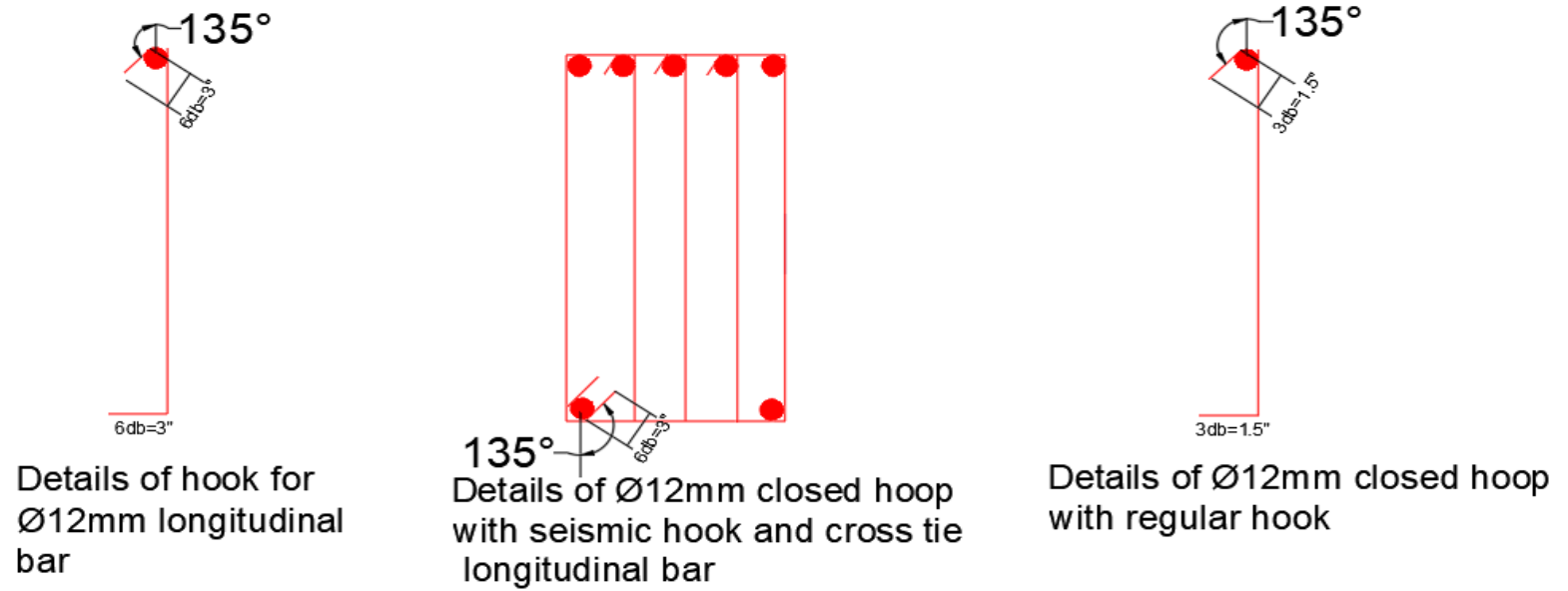

Figure 4.9c: Details of Closed Hoop and Cross Stirrup of Beam.

## Detailing of Column

This presents the detailed design of reinforced columns there are several columns in this building. All columns are analyzed by ETABS software. For space limitations, design of grid 8, frame H(C-3) of 2<sup>nd</sup> floor is presented here.

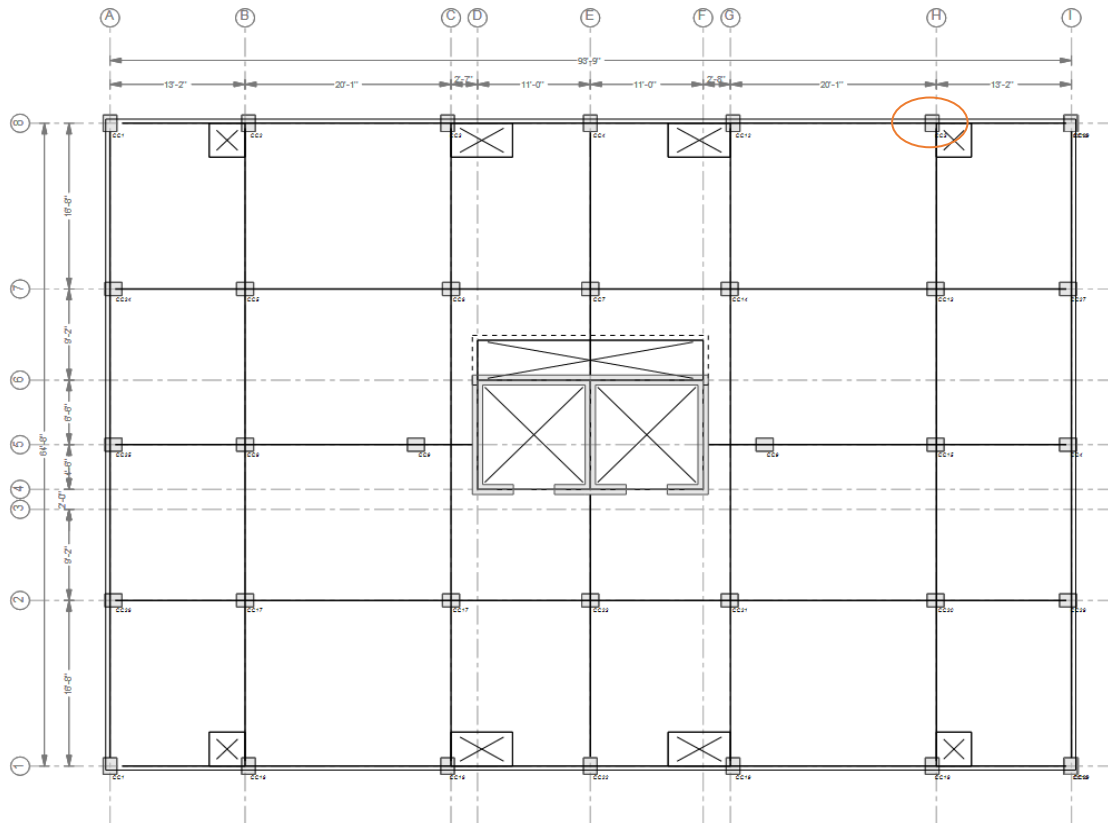

Figure 4.10: Floor column layout

### 1. Dimension of the column:

Assume the Size of column =  $b \times h = 16'' \times 22''$

### 2. Longitudinal reinforcement of column:

Moment, Shear, Axial Force and Steel area of the Column and details from ETABS, given below by Table 4.4.

Table 4.4: Longitudinal reinforcement of column

	<b>Top</b>	<b>Bottom</b>
<b>Axial Force, Pu</b>	999.17 Kip	1003.50 Kip
<b>Moment, Mu</b>	89.93 k-ft	-90.32 k-ft
<b>As (Required)</b>	13.50 in <sup>2</sup>	13.70 in <sup>2</sup>
<b>Required Bar</b>	Use 14 $\phi$ 28mmBar	Use 14 $\phi$ 28mmBar
<b>As (Provided)</b>	14 in <sup>2</sup>	14 in <sup>2</sup>

### 3. Transverse reinforcement of column:

There are three types of ties.

Table 4.5: Transverse/Shear Reinforcement of Column

	Top	Bottom
Shear Force, $V_u$	34.64 Kip	30.83 Kip
$A_v/S$ (Required)	$0.16 \text{ in}^2$	$0.16 \text{ in}^2$

#### (a) Seismic Tie

We use closed hoops with seismic hook. It is provided at a specified distance near both joints. Use  $\phi 12\text{mm}$  tie.

#### ❖ Spacing of the seismic tie:

First Condition-

$$S_o = \frac{\text{minimum dimension of Column}}{4} = \frac{16}{4} = 4''$$

Second Condition-

$$S_o = 6d_b = 6 \times \frac{9}{8} = 6.75''$$

From above condition, the minimum spacing  $S_o = 4.0'' \text{ c / c}$

#### ❖ Transverse reinforcement:

**Total transverse steel areas  $A_{sh}$**

Short direction

$$h_c = 22'' - 2 * [1.5 + \frac{4}{2 \times 8}] = 18.5''$$

$$A_{ch} = (16 - 2 * 1.5) \times (22 - 2 * 1.5) = 247 \text{ in}^2$$

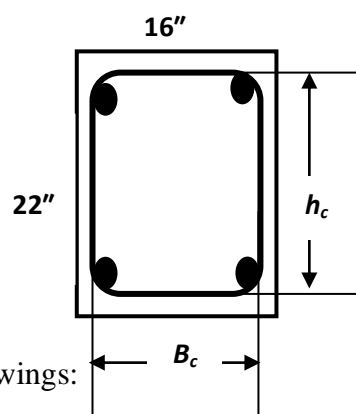

Total Transverse reinforcement will be larger of the followings:

$$A_{sh} > 0.09 \times S \times h_c \times \frac{f'_c}{f_{yh}} = 0.09 \times 4 \times 18.5 \times \frac{4}{60} = 0.44 \text{ in}^2$$

$$\begin{aligned} \text{Or } A_{sh} &> 0.30 \times S \times h_c \times \left( \frac{A_g}{A_{ch}} - 1 \right) \times \frac{f'_c}{f_{yh}} = 0.30 \times 4 \times 18.5 \times \left( \frac{16 \times 22}{247} - 1 \right) \times \frac{4}{60} \\ &= 0.63 \text{ in}^2 \text{ (governs)} \end{aligned}$$

Use  $\phi 12\text{mm}$  outside closed hoop.

Provided area =  $2 \times 0.20 = 0.40 \text{ in}^2 < 0.63 \text{ in}^2$ .

So, cross tie is required.

So,  $A_v = 0.63 - 0.40 = 0.23 \text{ in}^2$

Use  $2\phi 12\text{mm}$  cross ties are required

### Long direction

$$h_c = 16'' - 2 * [1.5 + \frac{4}{2 \times 8}] = 12.5''$$

$$A_{ch} = (16 - 2 * 1.5) \times (22 - 2 * 1.5) = 247 \text{ in}^2$$

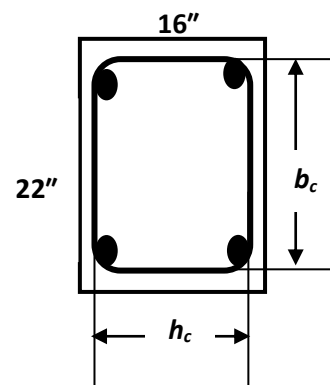

Total Transverse reinforcement will be larger of the followings:

$$A_{sh} > 0.09 \times S \times h_c \times \frac{f'_c}{f_{yh}} = 0.09 * 4 * 12.5 * \frac{4}{60} = 0.30 \text{ in}^2$$

$$\begin{aligned} \text{Or } A_{sh} &> 0.30 \times S \times h_c \times \left( \frac{A_g}{A_{ch}} - 1 \right) \times \frac{f'_c}{f_{yh}} = 0.30 \times 4 \times 12.5 \times \left( \frac{16 \times 22}{247} - 1 \right) \times \frac{4}{60} \\ &= 0.43 \text{ in}^2 (\text{governs}) \end{aligned}$$

For  $\phi 12\text{mm}$  outside closed hoop.

Provided areas =  $2 \times 0.20 = 0.40 \text{ in}^2 < 0.43 \text{ in}^2$ .

So, cross tie is required.

So,  $A_v = 0.43 - 0.40 = 0.03 \text{ in}^2$

No cross ties are required.

### ❖ Confinement length for transverse steel:

First condition-

$$l_o = \text{Depth of Column} = 22''$$

Second Condition-

$$l_o = \frac{\text{Clear span of column}}{6} = \frac{10 - \frac{20}{12}}{6} \times 12 = 16.67''$$

Third Condition

$$l_o = 18''$$

Provided confinement length from both center of joints,  $l_o = 22'' = 1.83'$

Total confinement length =  $2 l_o = 2 \times 1.83' = 3.67'$



### (b) Splice Tie

It is a closed hoop with seismic hook provided for splicing length of longitudinal bars. Generally lapping of bars is done at or near mid height of column.

#### ❖ Splicing length-

Splicing length must be 1.3 times of development length for  $\phi 28\text{mm}$  main bar which is calculated as below.

First condition

$$l_d = 0.04 \times A_b \times \frac{f_y}{\sqrt{f_{rc}}} = 0.04 \times 1 \times \frac{60000}{\sqrt{4000}} = 37.95''$$

Second condition-

$$l_d = 0.0004 \times d_b \times f_y = 0.0004 \times \frac{9}{8} \times 60000 = 27''$$

Third condition-

$$l_d = \text{minimum } 12''$$

From above condition, selected  $l_d = 37.95''$

Provided splicing length =  $1.30 \times 37.95'' = 49.34'' = 50''$

#### ❖ Spacing of tie

According to the ACI code the whole splicing zone should be confined by closed hoops with seismic hooks having the spacing calculated as below:

First condition-

$$S_{\max} = \frac{d}{4} = \frac{22 - 1.5 - 0.5 - \frac{1.125}{2}}{4} = 4.86'' \cong 4.5''$$

Second condition-

$$S_{\max} = \text{minimum } 4'' c / c$$

So, use  $\phi 12\text{mm}$  splicing ties @  $4'' c / c$

### (c) Regular Tie

Provided closed hoops having the spacing calculated as below:

First condition-

$$S_{\max} = 6d_b = 6 \times 1.13 = 6.78 \cong 6.5'' c/c$$

Second condition-

$$S_{\max} = 6'' c/c$$

So, use  $\phi 12\text{mm}$  regular ties @  $6'' c / c$

Other columns of the frame were designed as per similar procedure. The reinforcement detail of the column is shown in the Figures 4.11.

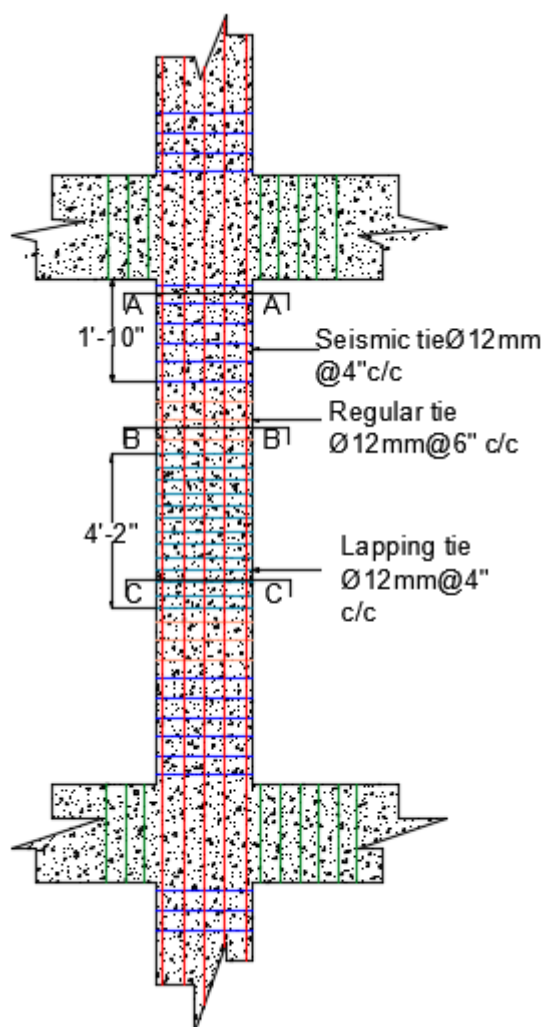

Figure 4.11a: Details of Longitudinal Section

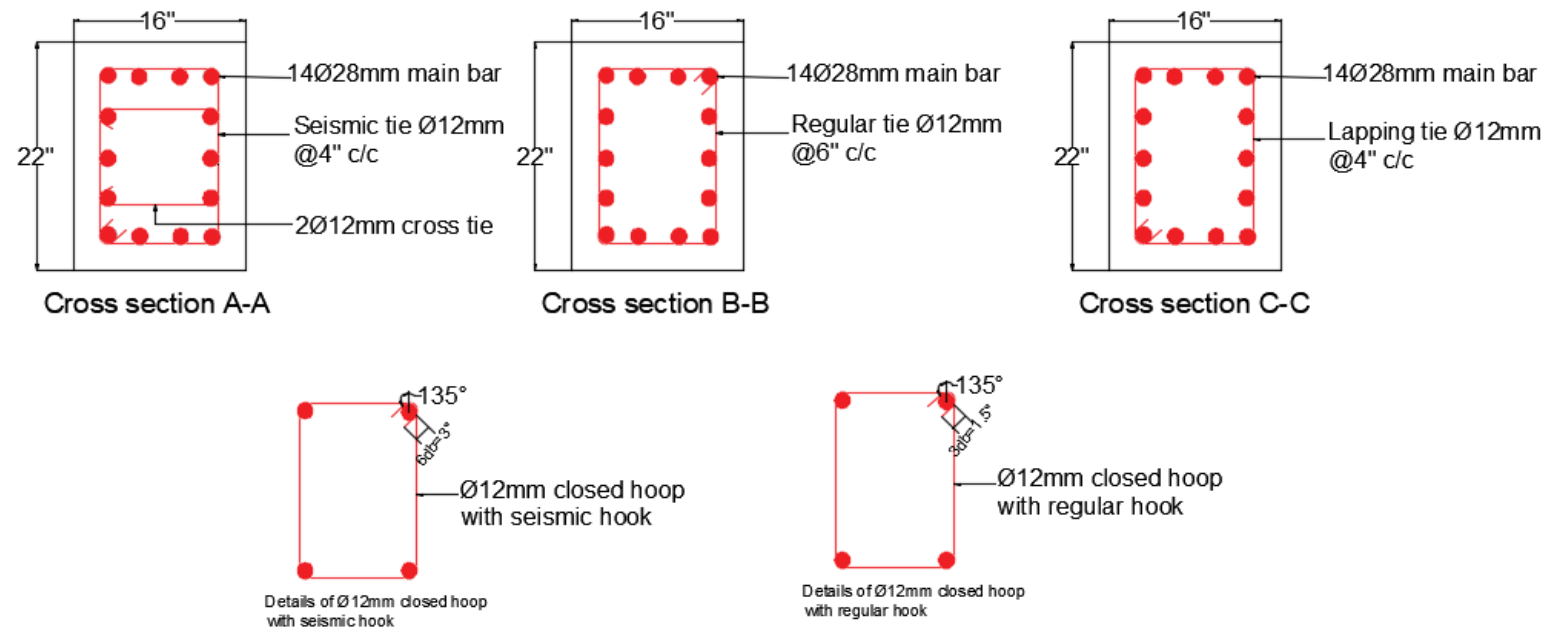

Figure 4.11b: Details of Cross Sections, Ties and Closed Hoops

### Detailing of Stair

There is one stair, starts from basement floor from roof top. Details of stair are given in Figure 4.12. All steps of the stair are supported on the lift-core wall as cantilever beam and its intermediate landing act as cantilever slab supported on the wall too.

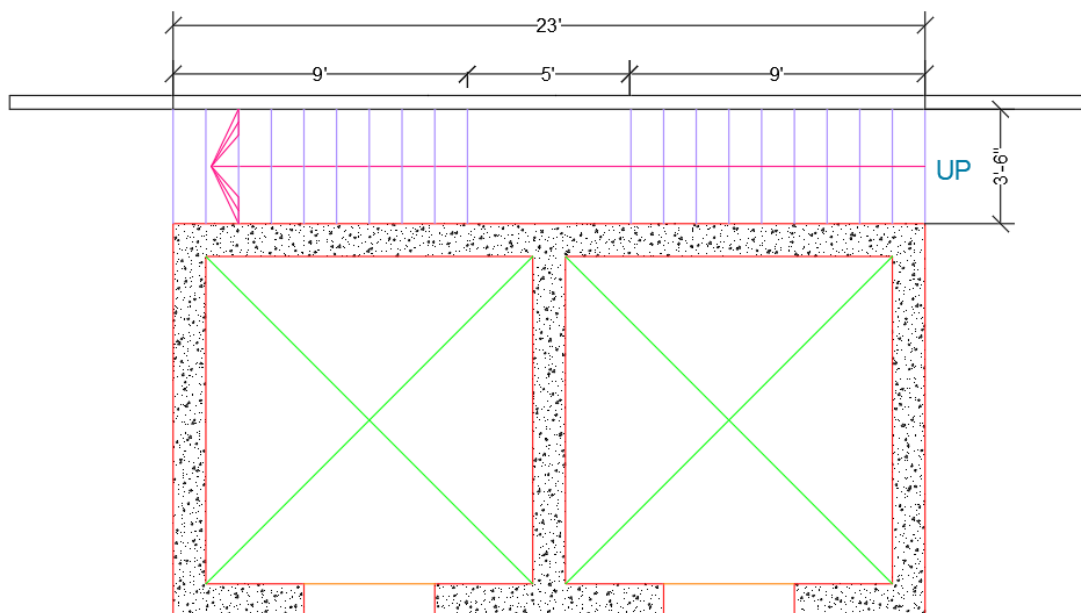

Figure 4.12a: Stair Plan

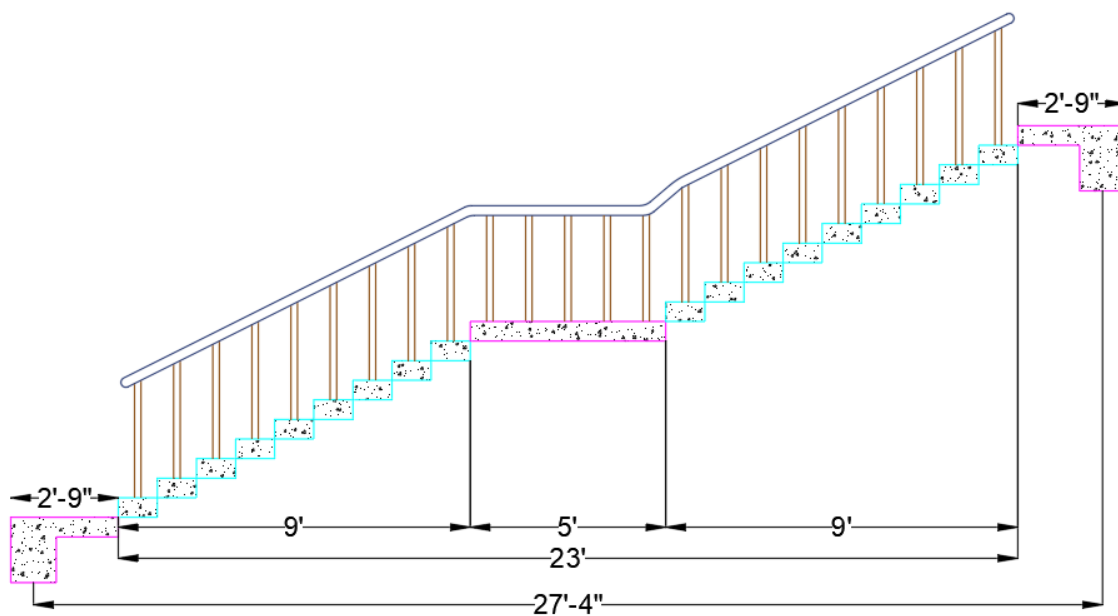

Figure 4.12b: Stair Elevation

**Design Data:**

- Stair Size = 23' x 4'-5"
- Height of flight = 5'
- Story height (except basement) = 10'
- Tread = 12"
- Rise = 6"
- No of Rise =  $\frac{\text{Ht. of flight}}{\text{Ht. of rise}} = \frac{5 \times 12}{6} = 10$  no of steps
- No of Trade = No of Rise – 1 = 10 - 1 = 9 no
- $f_y = 60,000 \text{ psi}$
- $f'_c = 4,000 \text{ psi}$
- F.F = 30 *psf*
- L.L = 100 *psf*

**Analysis and Design of cantilever stair step:** Each step having size 12"x6" acts as cantilever beam supported on lift-core. Length is 4'-5".

**I) Load calculation:**

$$1. \text{ Self-weight of stair step} = \frac{bh}{144} \times 150 = \frac{12 \times 6}{144} \times 150 = 75 \text{ lb/ft}$$

$$2. \text{ Floor finish} = 30 \text{ psf} = 30 \times 1 \text{ lb/ft} = 30 \text{ lb/ft}$$

$$\text{Total un-factored dead load} = 105 \text{ lb/ft}$$

$$\text{Total live load} = 100 \text{ psf} = 100 \times 1 \text{ lb/ft} = 100 \text{ lb/ft}$$

$$\text{Total Factored load, } W_f = 1.2 \times 105 + 1.6 \times 100 = 286 \text{ lb/ft} = 0.286 \text{ k/ft.}$$

**II) Moment Calculation & d Check:**

$$\text{Clear Span length} = 4.42' - \frac{6}{12} = 3.92'$$

$$M_u = \frac{Wl^2n}{2} = \frac{0.286 \times 3.92^2}{2} = 2.20 \text{ k-ft} = 26.4 \text{ k-in}$$

$$M_u = \phi \left[ \rho b d^2 f_y \left( 1 - 0.59 \rho \frac{f_y}{f'_c} \right) \right]$$

$$\Rightarrow 26.4 = 0.90 * [\rho * 12 * 4.5^2 * 60 \left( 1 - 0.59 * \rho * \frac{60}{4} \right)]$$

By solving,  $\rho_1 = 0.109$  and  $\rho_2 = 0.0020$

$$\rho_b = 0.85\beta_1 \frac{f'_c}{f_y} * \frac{87000}{87000 + f_y} = 0.85 * 0.85 * \frac{4000}{60000} * \frac{87000}{87000 + 60000} = 0.0285$$

$$\rho_{\max} = 0.75\rho_b = 0.75 * 0.0285 = 0.0214$$

$$\rho_{\min} = \frac{3\sqrt{f'_c}}{f_y} = \frac{3\sqrt{4000}}{60000} = 0.0032$$

$$\rho_{\min} = \frac{200}{f_y} = \frac{200}{60000} = 0.0033$$

Based on minimum and maximum steel ratios, selected,  $\rho = 0.0033$

$$M_u = \phi \rho b d^2 f_y \left( 1 - 0.59 \rho \frac{f_y}{f'_c} \right) \Rightarrow 26.4 = 0.90 * 0.0033 * 12 * d^2 * 60 * \left( 1 - 0.59 * 0.0033 * \frac{60}{4} \right)$$

$$\Rightarrow d = 3.57" < d = 4.5" \text{ (so ok)}$$

### Reinforcement requirements

$$A_s = \rho b d = 0.0033 \times 12 \times 4.5 = 0.18 \text{ in}^2$$

Use 2 $\phi$ 16mm at top the steps,  $A_s \text{ provided} = 2 \times 0.31 = 0.62 \text{ in}^2$

Use  $\phi$ 10mm u-stirrup @  $\frac{d}{2} = \frac{4.5}{2} = 2.25 \equiv 2" \text{ c/c}$  for the entire length of the steps. Also use 2 $\phi$ 16mm bars at bottom to hold up the stirrups.

### B] Analysis and Design of Intermediate landing cantilever slab:

This acts as cantilever slab having thickness 6" supported on lift-core. Free length is 4'-5"

#### Load calculation

$$1. \text{ Self-weight} = \frac{h}{12} \times 150 = \frac{6}{12} \times 150 = 75 \text{ psf}$$

$$2. \text{ Floor finish} = 30 \text{ psf}$$

Total un-factored dead load = 105 psf

Total live load = 100 psf

Total Factored load,  $W_t = 1.2 * 105 + 1.6 * 100 = 286 \text{ psf} = 286 \times 1 \text{ lb/ft} = 0.286 \text{ k/ft}$ .

**Moment calculation**

Clear Span length = 3.92'

$$M_u = \frac{wl^2n}{2} = \frac{0.286 \times 3.92^2}{2} = 2.20 \text{ k-ft} = 26.4 \text{ k-in}$$

**Check for "d"**

$$M_u = \phi \rho b d^2 f_y \left( 1 - 0.59 \rho \frac{f_y}{f'_c} \right)$$

$$\Rightarrow 26.4 = 0.90 * 0.0214 * 12 * d^2 * 60 * \left( 1 - 0.59 * 0.0214 * \frac{60}{4} \right)$$

$$\Rightarrow d = 1.5" < d = 5" \text{ (so ok)}$$

 **$A_s$  calculation****Main steel**

$$M_u = 26.4 \text{ k-in}$$

$$\rho = \frac{0.85 f'_c}{f_y} \left[ 1 - \sqrt{1 - \frac{2M_u}{0.85 * \phi * f'_c * b * d^2}} \right]$$

$$= \frac{0.85 * 4}{60} \left[ 1 - \sqrt{1 - \frac{2 * 26.4}{0.85 * 0.90 * 4 * 12 * 5^2}} \right]$$

$$= 0.0032 > 0.0018$$

$$\text{Selected } \rho = 0.0032$$

$$A_s = \rho b d = 0.0032 * 12 * 5 = 0.192 \text{ in}^2/\text{ft}$$

$$\text{Use } \phi 10 \text{ mm bar and spacing} = \frac{0.11 * 12}{0.192} = 6.87" \equiv 6.5" \text{ c/c}$$

$$s_{max} = 3h = 18"$$

$$s_{max} = 18"$$

Use  $\phi 10 \text{ mm}$  @ 6.5" c/c in the cantilever direction at top.

### Temperature & Shrinkage bar

$$A_s = 0.0018 b * h$$

$$= 0.0018 * 12 * 6 = 0.130 \text{ in}^2/\text{ft}$$

Use  $\phi 10\text{mm}$  bar, area is  $0.11 \text{ in}^2$

$$\text{Spacing} = \frac{0.11 * 12}{0.130} = 10.15 \equiv 10" \text{ c/c}$$

Use  $\phi 10\text{mm}$  @  $10" \text{ c/c}$  below the main bar in opposite direction.

Details of reinforcement arrangement are shown in Figure 4.13.

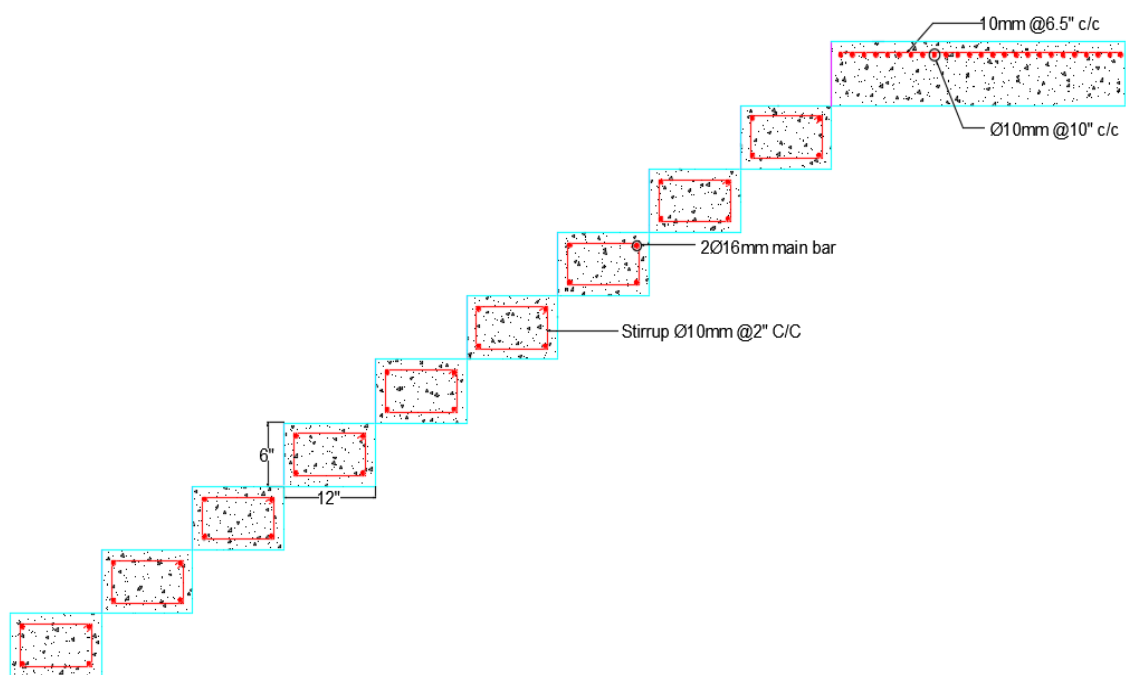

Figure 4.13: Reinforcement Details of Stair



### Design of Ramp

Two ramps are provided at entry and exit, having. Each ramp is straight having inclination angle of 15 degrees and supported on concrete wall and ends on basement which is 7ft below the road level.

#### Design data:

$$f_y = 60,000 \text{ psi}$$

$$f'_c = 4,000 \text{ psi}$$

$$\text{L.L} = 15 \text{ psf}$$

$$\text{F.F} = 10 \text{ psf}$$

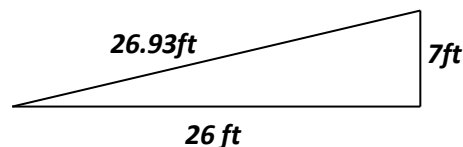

$$\text{Span length} = 26.93 \text{ ft}$$

$$\text{Ramp Width} = 13.92 \text{ ft}$$

$$\text{Vehicular Load} = 50 \text{ psf}$$

$$\text{Let, thickness of Ramp} = \frac{L}{18.5} = \frac{26 \times 12}{18.5} = 16.86 \approx 17 \text{ in}$$

$$d = (17 - 1.5) = 15.5 \text{ in}$$

#### Load calculation:

$$\begin{aligned} 1. \text{ Self-weight of Ramp slab} &= \frac{17}{12} * 150 * \frac{1}{\cos \theta} & [\cos \theta = \frac{26}{26.93} = 0.97] \\ &= \frac{17}{12} * 150 * \frac{1}{0.97} = 219.07 \text{ psf} \end{aligned}$$

$$2. \text{ F.F} = 10 \text{ psf}$$

$$3. \text{ Vehicular Load} = 50 \text{ psf}$$

$$4. \text{ L.L} = 15 \text{ psf}$$

$$\text{Factored load, } W_t = 1.2 (219.07 + 10) + 1.6 (50 + 15) = 378.88 \text{ lb/ft}$$

#### Moment calculation:

$$- \text{Ve Moment at Ext.} = \frac{1}{24} W_t l_n^2 = \frac{378.88 \times 26.93^2}{24} = 11448.88 \text{ lb-ft} = 11.45 \text{ k-ft}$$

$$+ \text{Ve Moment at mid span} = \frac{1}{14} W_t l_n^2 = \frac{378.88 \times 26.93^2}{14} = 19626.66 \text{ lb-ft} = 19.63 \text{ k-ft}$$

$$- \text{Ve Moment at Int.} = \frac{1}{9} W_t l_n^2 = \frac{378.88 \times 26.93^2}{9} = 30530.36 \text{ lb-ft} = 30.53 \text{ k-ft}$$

**Check for “d”:**

$$\rho_b = 0.85\beta_1 \frac{f'_c}{f_y} * \frac{87000}{87000 + f_y} = 0.85 * 0.85 * \frac{4000}{60000} * \frac{87000}{87000 + 60000} = 0.0285$$

$$\rho_{\max} = 0.75\rho_b = 0.75 * 0.0285 = 0.0214$$

$$M_u = \phi\rho b d^2 f_y \left(1 - 0.59\rho \frac{f_y}{f'_c}\right)$$

$$\Rightarrow 30.53 * 12 = 0.90 * 0.0214 * 12 * d^2 * 60 * \left(1 - 0.59 * 0.0214 * \frac{60}{4}\right)$$

$$\Rightarrow d = 5.71" < d = 15.5" \text{ (so ok)}$$

**A<sub>s</sub> calculation:**

**Main steel**

+ Ve steel for Mid Span

$$M_u = 19.63 \text{ k-ft} = 235.56 \text{ k-in}$$

$$\rho = \frac{0.85f'_c}{f_y} \left[1 - \sqrt{1 - \frac{2M_u}{0.85 * \phi * f'_c * b * d^2}}\right]$$

$$= \frac{0.85 * 4}{60} \left[1 - \sqrt{1 - \frac{2 * 235.56}{0.85 * 0.90 * 4 * 12 * 15.5^2}}\right]$$

$$= 0.0015 < 0.0018$$

$$\text{Selected } \rho = 0.0018$$

$$A_s = \rho b d = 0.0018 * 12 * 15.5 = 0.335 \text{ in}^2/\text{ft}$$

Use  $\phi 16\text{mm}$  bar and spacing =  $(0.31 * 12) / 0.335 = 11.10" \equiv 11" \text{ c/c}$

Use  $\phi 16\text{mm}$  @ 11" c/c which will be alternated cranked at the supports.

- Ve steel for Ext support

$$M_u = 11.45 \text{ k-ft} = 137.4 \text{ k-in}$$

$$\rho = \frac{0.85 f_c'}{f_y} \left[ 1 - \sqrt{1 - \frac{2M_u}{0.85 * \phi * f_c' * b * d^2}} \right]$$

$$= \frac{0.85 * 4}{60} \left[ 1 - \sqrt{1 - \frac{2 * 137.4}{0.85 * 0.90 * 4 * 12 * 15.5^2}} \right] = 0.00089 < 0.0018$$

So selected  $\rho = 0.0018$

$$A_s = \rho b d = 0.0018 * 12 * 15.5 = 0.335 \text{ in}^2/\text{ft.}$$

$$\text{Required Extra top} = \frac{0.335 * 22}{12} - 0.31 = 0.31 \text{ in}^2/\text{ft.}$$

Use 2  $\phi$ 12mm bar as extra top in between two ckd. bars

-Ve steel for Int. support

$$M_u = 30.53 \text{ k-ft} = 366.36 \text{ k-in}$$

$$\rho = \frac{0.85 f_c'}{f_y} \left[ 1 - \sqrt{1 - \frac{2M_u}{0.85 * \phi * f_c' * b * d^2}} \right]$$

$$= \frac{0.85 * 4}{60} \left[ 1 - \sqrt{1 - \frac{2 * 366.36}{0.85 * 0.90 * 4 * 12 * 15.5^2}} \right]$$

$$= 0.0024 > 0.0018$$

$$A_s = \rho b d = 0.0024 * 12 * 15.5 = 0.446 \text{ in}^2/\text{ft.}$$

$$\text{Required Extra top} = \frac{0.446 * 22}{12} - 0.31 = 0.51 \text{ in}^2$$

Use 3- $\phi$ 12mm bar as extra top in between two ckd. bars.

### Temperature & Shrinkage bar

$$A_s = 0.0018 b * h$$

$$= 0.0018 * 12 * 17 = 0.367 \text{ in}^2/\text{ft}$$

Use  $\phi 16\text{mm}$  bar, area is  $0.31 \text{ in}^2$

$$\text{Spacing} = \frac{0.31 * 12}{0.367} = 10.13" = 10" \text{ c/c}$$

Use  $\phi 16\text{mm}$  @  $10" \text{ c/c}$  above the main bar.

Details of sectional dimensions and reinforcement arrangement of ramp are presented in Figure 4.14.

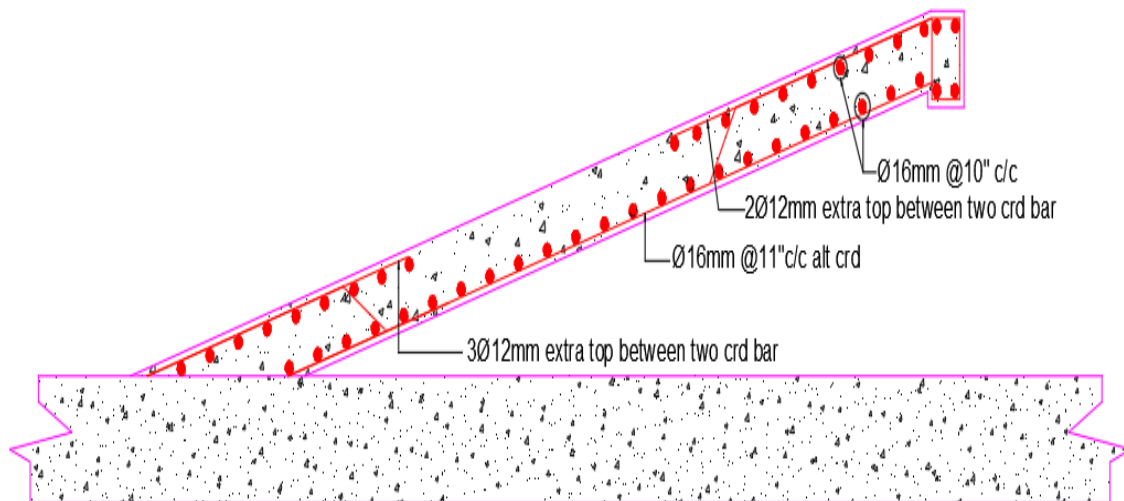

Figure 4.14: Details of reinforcement arrangement

### Detailing of Lift Core (Shear Wall)

This gives details of lift core design for lateral loadings. There are two lift cores in this building. Lift core was analyzed, designed and detailed by ETABS 2016 Software. Allocation of lift core, detailing of lift core of ground floor level and roof level is presented in Figures 4.15 ~ 4.16.

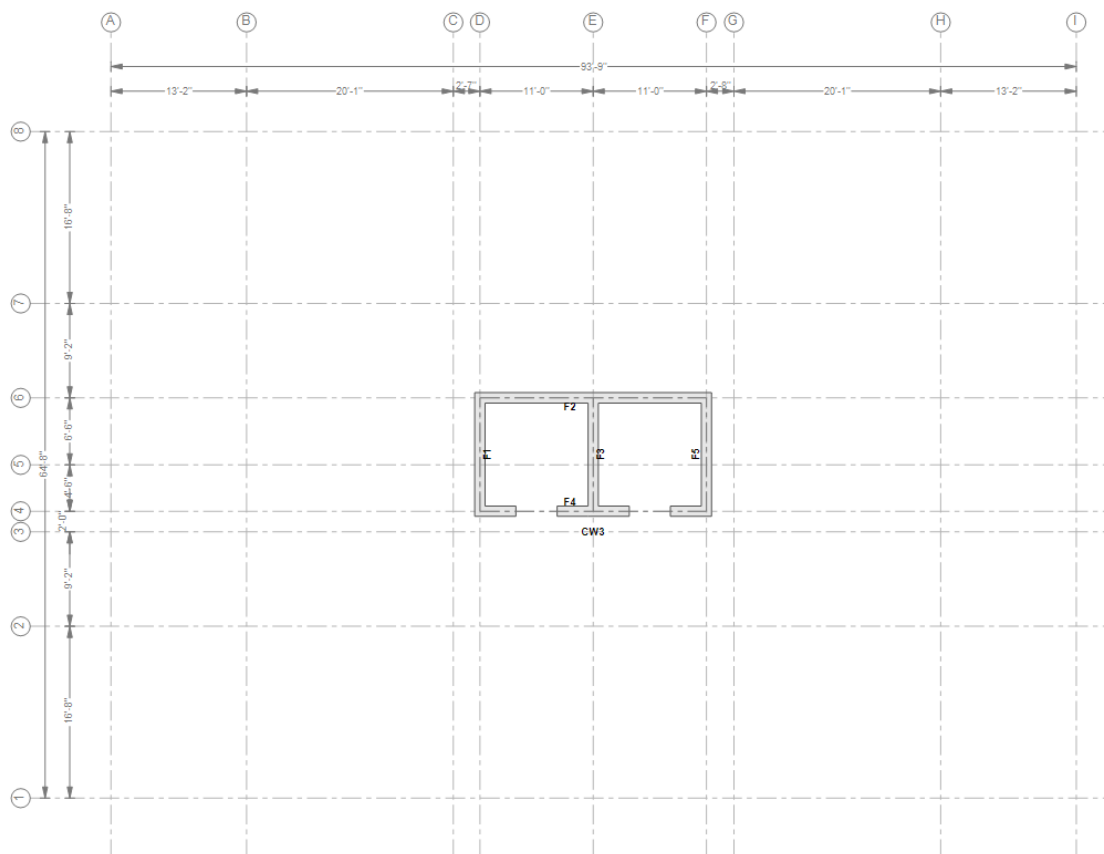

Figure 4.15: Wall Layout Plan

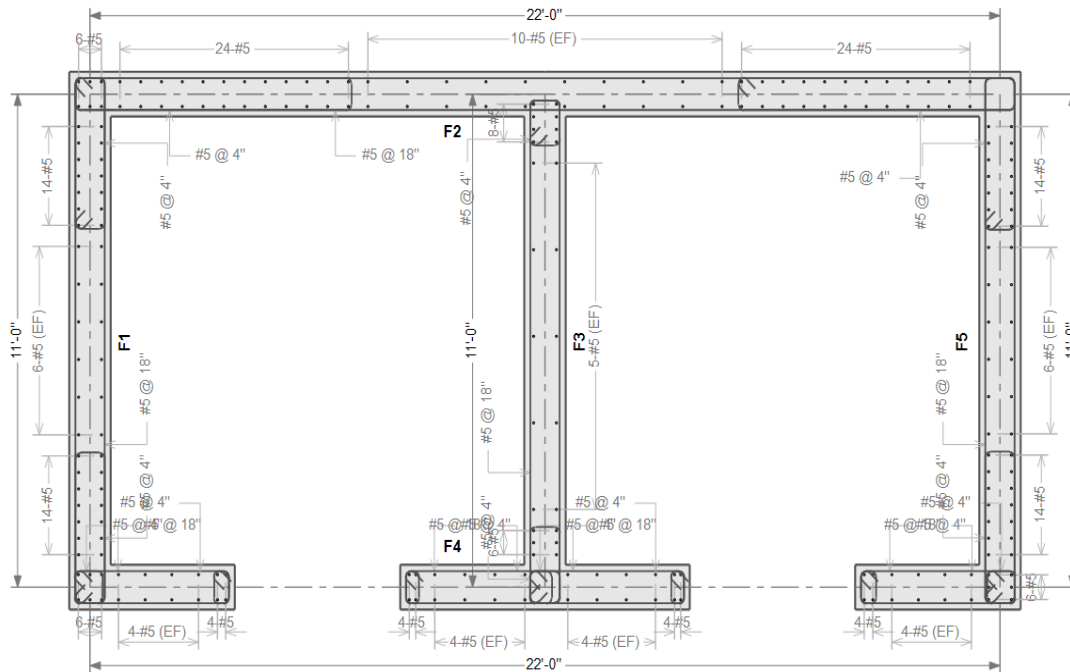

Figure 4.16a: Lift Core Section (At GF Floor Level)

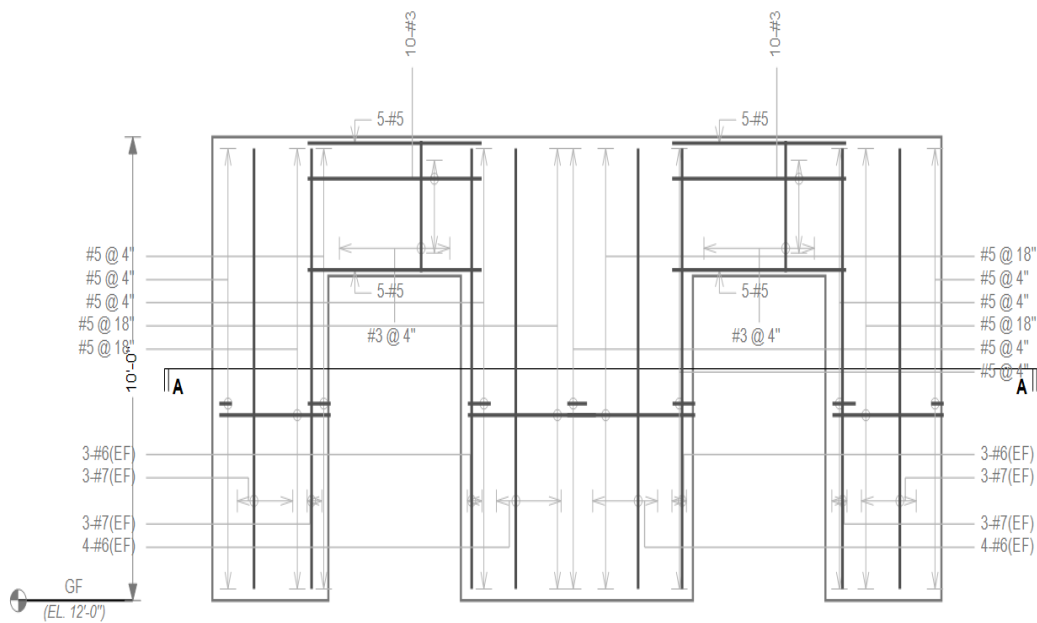

Figure 4.16b: Reinforcement arrangement of Spandrel (At GF Floor Level)

### **Detailing of Overhead Head Water Tank**

There are one overhead water tanks constructed. For space limitations, design of OHWT, the layout of OWHT are shown in Figure 4.17.

Length	= 22'
Width	= 11'
Tank height	= 6.5'
Free board	= 0.5'
Total tank height	= 6.5+0.5 = 7'
Select tank size	= 22' × 11' × 7'

Over Head Water Tank are analyzed, designed and detailed by ETABS and SAFE software. The layout of OWHT are shown in Figure 4.16. Details of reinforcement arrangement of OWHT are shown in Figures 4.17-4.19.

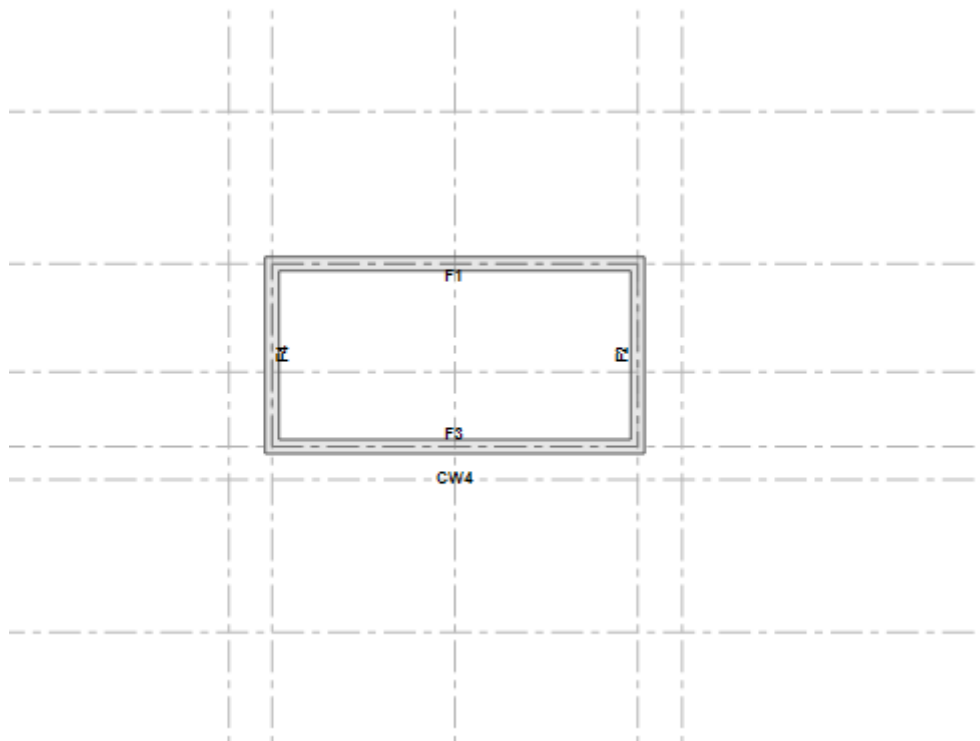

Figure 4.17: Overhead Water Tank Layout Plan

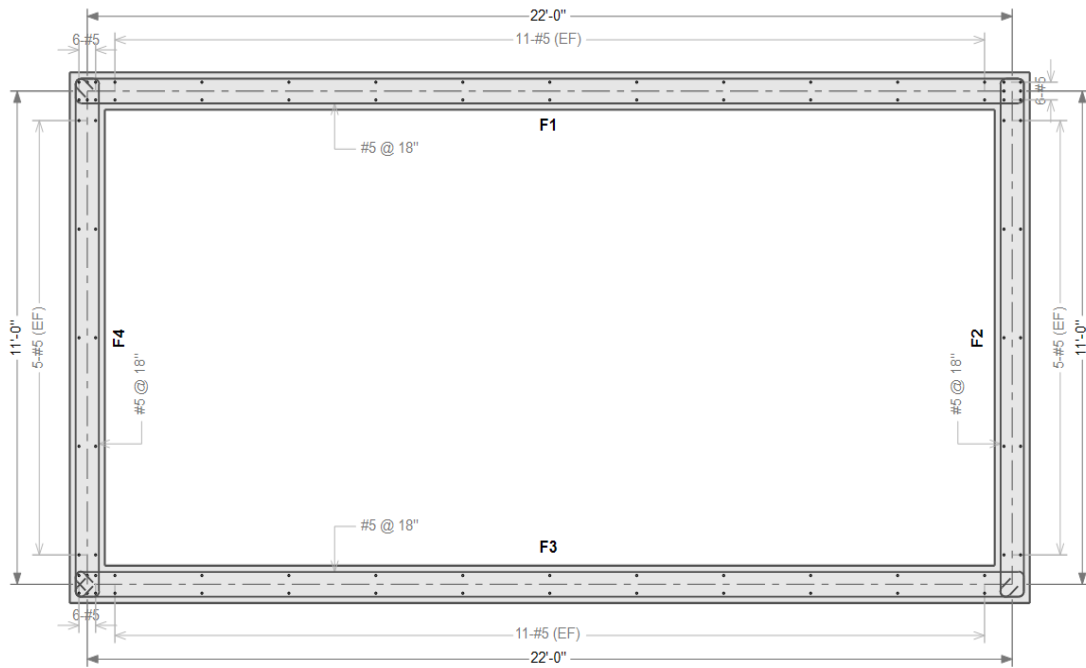

Figure 4.18: Reinforcement details of Over Head Water Tank wall cross section.

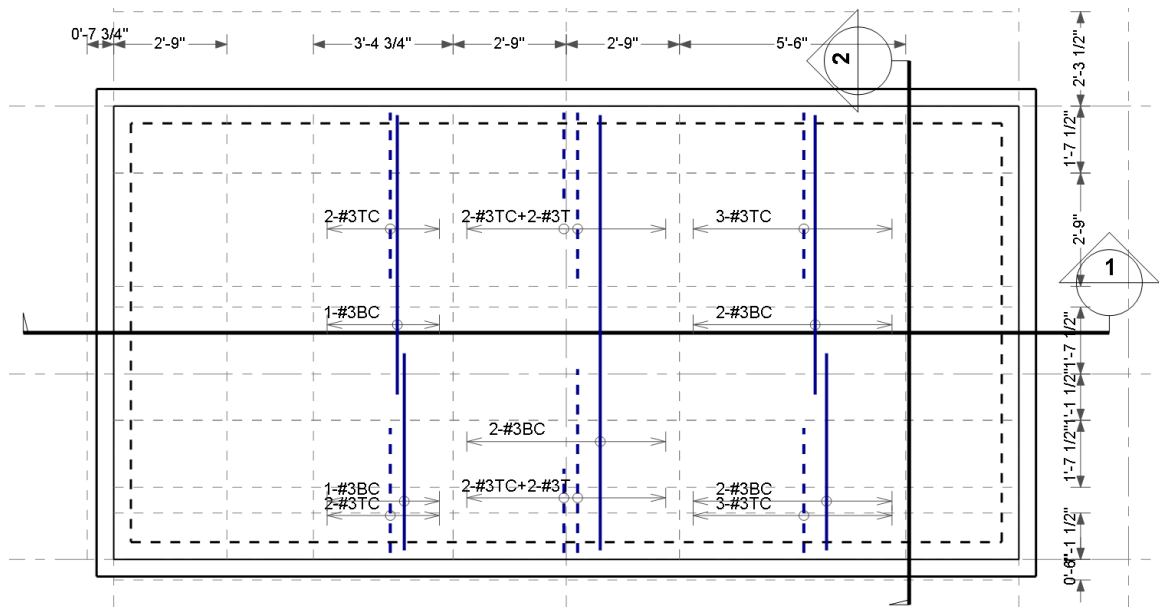

Figure 4.19a: Slab detailing OWHT (Top)



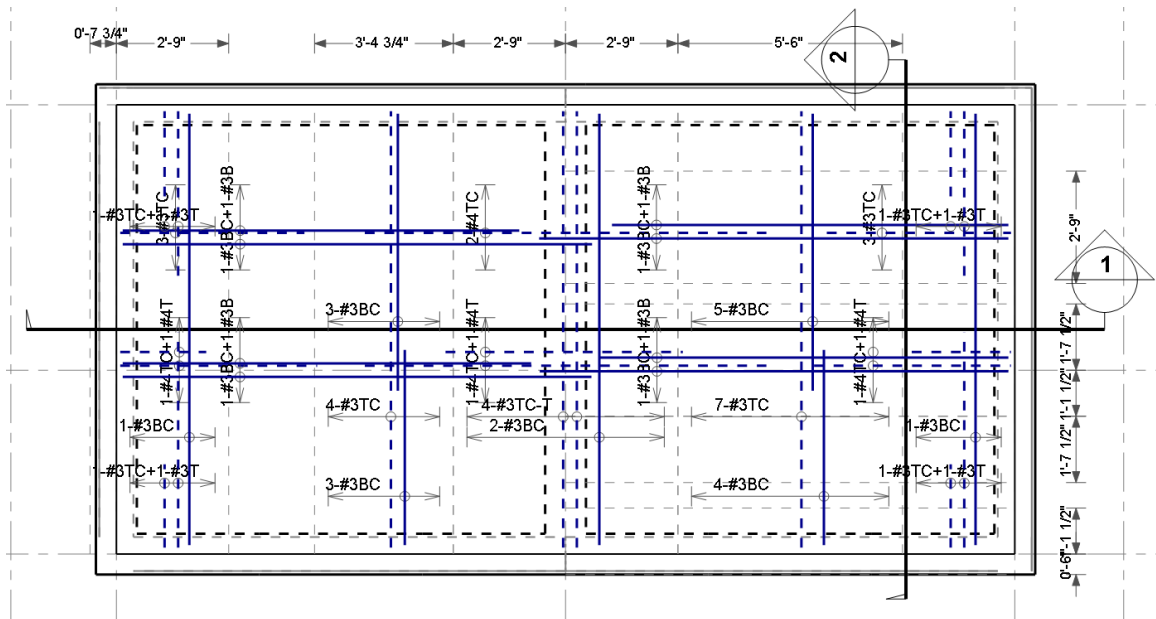

Figure 4.19b: Slab detailing OWHT (Bottom)

**Detailing of Underground Water Reservoir**

There are four underground water reservoirs (11.5' x 27') on soil for fulfilling the water demand of the building. Water storage is made also considering one-hour Fire Fighting works. The design of this water tank will be done as per WSD. UGWR are shown in Figures 4.20

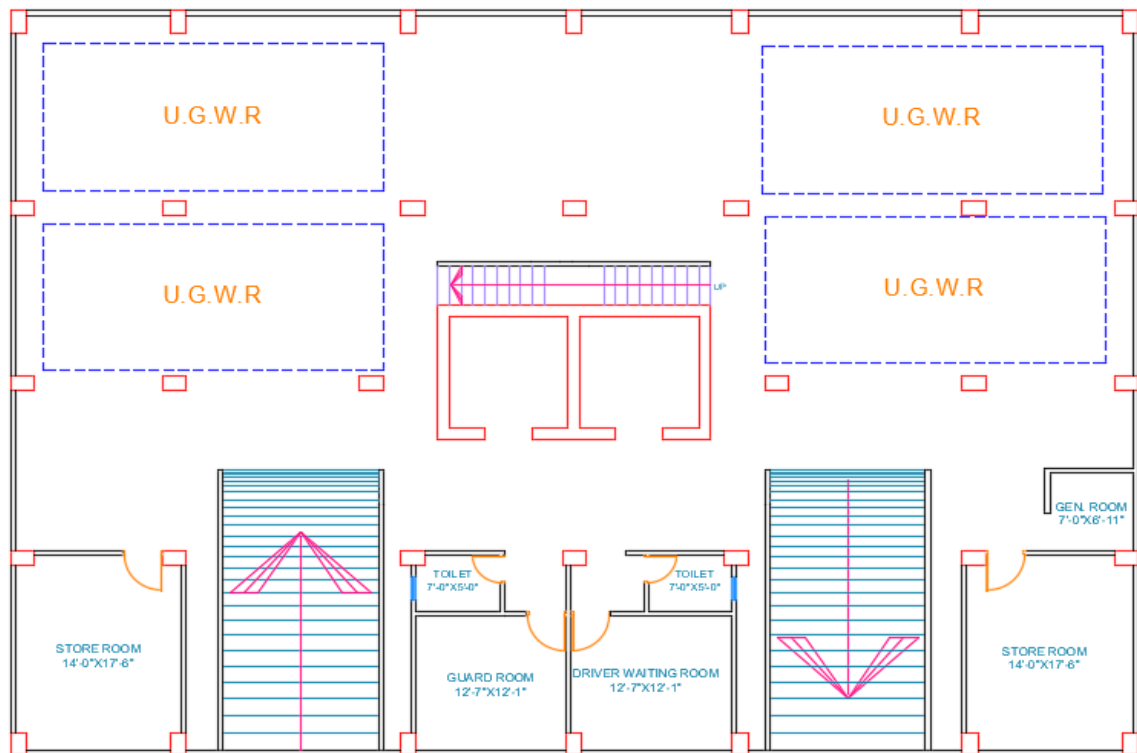

Figure 4.20: Water Tank Layout Plan

### ***Determination of water requirement***

#### **\* Residential purposes**

Water requirement	= 225 L/P/D
No. of floor	= 16
No of Unit floor	= 4
No. of person per unit	= 8 (Assume)
Total required volume of water	= $225 \times 16 \times 4 \times 8 = 115200$ L/P/D

#### **\* Garage purposes**

Water requirement	= 70 L/P/D
No. of floor	= 2
No. of person per unit	= 25 (Assume)
Total required volume of water	= $70 \times 25 \times 2 = 3500$ L/P/D

#### **\* Fire safety purposes**

Consider, water storage for 1 hr. fire fighting,

Water requirement for 1 floor	= 265 gal/min
	= $265 \times 60$ gal/hr = 15900 gal/hr
$\therefore$ Water requirement for two floor	= $2 \times 15900$ gal
	= 31800 gal
	= 120376 L

Total water requirement for whole structures =  $(120376 + 3500 + 115200)$  L  
= 239076 L

$\therefore$  Total Water requirement for tank = 239076 L =  $239.08$  m<sup>3</sup>  
=  $239.08 \times 3.28^3$  ft<sup>3</sup>  
= 8436.55 ft<sup>3</sup>

Water requirement for tank for one =  $8436.55 / 4 = 2109.14$  ft<sup>3</sup>

### **Tank dimension**

Inside width dimension,  $B = 11.5$  ft

Height = 6.5 ft

Free board = 0.5 ft

Final height =  $6.5 + 0.5 = 7$  ft

So inside length dimension,  $L = 2109.14 / (11.5 \times 7) = 26.20$  ft = 27 ft

Hence the dimension of the tank compartment will be 11.5 ft wide and 27 ft long.

### A. Design of long walls

Both long walls will be designed considering empty condition.

$$\begin{aligned} \text{Pressure exerted by dry soil} &= wh \frac{1 - \sin \phi}{1 + \sin \phi} \\ &= 20 \times 2.13 \times \frac{1 - \sin 30}{1 + \sin 30} = 14.2 \text{ kN/m}^2 \\ \therefore p &= 14.2 \text{ kN/m}^2 \end{aligned}$$

Thickness of the wall:

Moment at outer face of long wall,

$$\begin{aligned} \frac{ph^2}{33.5} &= \frac{14.2 \times 2.13^2}{33.5} = 1.923 \text{ kN-m/m} \\ &= \frac{1.923 \times 1000}{4.448 \times 0.3048} \times \frac{12}{1000} \\ &= 17.02 \text{ k-in} \\ &\text{(Per meter run)} \end{aligned}$$

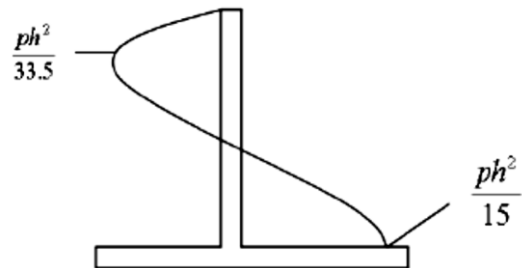

So, Moment per feet run =  $17.02 \times 0.3048 = 5.19 \text{ k-in/ft}$

Moment at inner face of long wall,

$$\begin{aligned} M_{\max} &= \frac{ph^2}{15} = \frac{14.2 \times 2.13^2}{15} = 4.29 \text{ kN-m/m} \\ &= 37.97 \text{ k-in (per meter run)} = 11.57 \text{ k-in (per ft run)} \end{aligned}$$

From cracking consideration, the thickness of long wall will be determined.

D = total thickness of tank wall,

$$\begin{aligned} M &= \frac{f_{ct} b D^2}{6} \\ \therefore D^2 &= \frac{6 \times 11.57}{0.410 \times 12} \\ D &= 3.76" \equiv 10.0" \text{ (preferable minimum thickness)} \end{aligned}$$

[ Here  $f_{ct} = (6 \rightarrow 8) \sqrt{f_c}$

$$\text{Let, } f_{ct} = 7.5 \sqrt{f_c} = 7.5 \times \sqrt{3000} = 410.79 \text{ psi}]$$

$\therefore$  Effective depth =  $10 - 1.5 = 8.50 \text{ inch}$

**Vertical reinforcement:**

$$f'_c = 3000 \text{ psi}$$

$$f_c = 0.45 f'_c = 0.45 \times 3000 = 1350 \text{ psi}$$

$$f_y = 60,000 \text{ psi.}$$

$$f_s = 0.50 f_y = 0.50 \times 60000 = 30000 \text{ psi}$$

$$E_s = 29 \times 10^6 \text{ psi}$$

$$E_c = 57,000\sqrt{3000} = 3.1 \times 10^6 \text{ psi}$$

$$n = \frac{E_s}{E_c} = \frac{29 \times 10^6}{3.1 \times 10^6} = 9$$

$$r = \frac{f_s}{f_c} = \frac{30000}{1350} = 22.22$$

$$k = \frac{n}{n+r} = \frac{9}{9+22.22} = 0.288$$

$$J = 1 - \frac{k}{3} = 1 - \frac{0.288}{3} = 0.904$$

**Vertical Reinforcement for inner face of wall**

$$M = 11.57 \text{ k-in (per ft run)}$$

$$\text{Steel requirement, } A_s = \frac{M}{f_s j d} = \frac{11.57 \times 1000}{30000 \times 0.904 \times 8.5} = 0.050 \frac{\text{in}^2}{\text{ft}}$$

$$\text{Minimum } A_s = 0.003bh = 0.003 \times 12 \times 10 = 0.36 \text{ in}^2 / \text{ft}$$

$$\text{Selected } A_s = 0.36 \text{ in}^2/\text{ft.}$$

$$\text{Use } \phi 12\text{mm, spacing} = \frac{0.20 \times 12}{0.36} = 6.67" \cong 6.5" \text{ c / c}$$

$$S_{\max} = 3h = 3 \times 10" = 30" \text{ and } S_{\max} = 18"$$

So, use  $\phi 12\text{mm @ } 6.5" \text{ c/c.}$

**Vertical Reinforcement for outer face of wall**

$$M = 5.19 \text{ kip-in (per ft run).}$$

$$A_s = \frac{M}{f_s j d} = \frac{5.19 \times 1000}{30000 \times 0.904 \times 8.5} = 0.023 \text{ in}^2/\text{ft}$$

$$\text{Minimum } A_s = 0.003bh = 0.003 \times 12 \times 10 = 0.36 \text{ in}^2 / \text{ft}$$

$$\text{Selected } A_s = 0.36 \text{ in}^2/\text{ft.}$$

$$\text{Use } \phi 12\text{mm, spacing} = \frac{0.20 \times 12}{0.36} = 6.67" \cong 6.5" \text{ c / c}$$

So, use  $\phi 12\text{mm @ } 6.5" \text{ c/c.}$

**Horizontal reinforcement:**

Minimum steel will be placed as binder.

$$\text{Minimum } A_s = 0.003bh = 0.003 \times 12 \times 10 = 0.36 \text{ in}^2 / \text{ft}$$

$$\text{Use } \phi 12 \text{mm, spacing} = \frac{0.20 \times 12}{0.36} = 6.67" \equiv 6.5" \text{ c / c}$$

So, use  $\phi 12 \text{mm} @ 6.5" \text{c/c}$  at both faces.

**B. Design of short wall**

Earth pressure at the bottom,  $P = 14.2 \text{ kN/m}^2$

$$\text{Max moment at the center, } M = \frac{PL^2}{12}$$

$$L = 11.5 + \frac{10}{12} = 12.33 \text{ ft} = 3.76 \text{ m}$$

$$M = \frac{14.2 * 3.76^2}{12} = 16.73 \text{ k-in/meter} = 4.43 \text{ k-in/ft}$$

Now check 'd',

$$M_{\max} = \frac{f_c}{2} j k b d^2$$

$$\therefore d = \sqrt{\frac{2 * 4.43}{1.35 * 0.288 * 0.904 * 12}} = 1.44" < \text{provided } d = 8.5" \text{ ok.}$$

**Vertical reinforcement:**

$M = 4.43 \text{ kip-in}$  (per ft run).

$$A_s = \frac{M}{f_s j d} = \frac{4.43 * 1000}{30000 * 0.904 * 8.5} = 0.019 \text{ in}^2 / \text{ft}$$

$$\text{Minimum } A_s = 0.003bh = 0.003 \times 12 \times 10 = 0.36 \text{ in}^2 / \text{ft}$$

Selected  $A_s = 0.36 \text{ in}^2 / \text{ft}$ .

$$\text{Use } \phi 12 \text{mm, spacing} = \frac{0.20 \times 12}{0.36} = 6.67" \equiv 6.5" \text{ c / c}$$

So, use  $\phi 12 \text{mm} @ 6.5" \text{c/c}$  at both faces.

**Horizontal reinforcement:**

Minimum steel will be placed as binder.

$$\text{Minimum } A_s = 0.003bh = 0.003 \times 12 \times 10 = 0.36 \text{ in}^2 / \text{ft}$$

$$\text{Use } \phi 12 \text{mm, spacing} = \frac{0.20 \times 12}{0.36} = 6.67" \approx 6.5" \text{ c/c}$$

So, use  $\phi 12 \text{mm} @ 6.5" \text{c/c}$  at both faces.

**A. Design of top slab**

$$\frac{L}{B} = \frac{27}{11.5} = 2.35 \geq 2$$

So, it is a one- way slab.

Minimum thickness of the slab,

$$h = \frac{11.5}{20} \times 12 = 6.7" \text{ And take } h = 10"$$

**Load calculation:**

$$\text{Live load} = 10 \text{ psf}$$

$$\text{Self-weight of the slab} = \frac{10}{12} \times 150 = 124.5 \text{ psf}$$

$$\text{Floor finish (assume)} = 10 \text{ psf}$$

$$\text{Vehicular load} = 50 \text{ psf}$$

---

$$\text{Total load, } W = 194.5 \text{ psf} = 0.195 \text{ ksf}$$

**d check:**

Moment in short direction

$$M = \frac{wL^2}{3} = \frac{0.195 \times 13.17^2}{3} = 11.27 \text{ k-ft}$$

$$L = 11.5 + \frac{20}{12} = 13.17 \text{ ft}$$

$$\therefore d = \sqrt{\frac{2 \times 11.27 \times 12}{1.35 \times 0.288 \times 0.904 \times 12}} = 8" < \text{ provided } d = 10 - 1 = 9" \text{ ok.}$$

**Reinforcement calculation:**

- **Main steel**

$M = 11.27 \text{ kip-ft} = 135.24 \text{ kip-in}$  (per ft run).

$$A_s = \frac{M}{f_s j d} = \frac{135.24 * 1000}{30000 * 0.904 * 9} = 0.55 \text{ in}^2 / \text{ft}$$

$$\text{Minimum } A_s = 0.003bh = 0.003 * 12 * 10 = 0.36 \text{ in}^2 / \text{ft}$$

Selected  $A_s = 0.55 \text{ in}^2 / \text{ft}$ .

$$\text{Use } \phi 12 \text{mm, spacing} = \frac{0.20 * 12}{0.55} = 4.34" \equiv 4" \text{ c/c}$$

So, use  $\phi 12 \text{mm} @ 4" \text{ c/c}$ .

- **Distribution Reinforcement**

$$\text{Minimum } A_s = 0.003bh = 0.003 * 12 * 10 = 0.36 \text{ in}^2 / \text{ft}$$

Selected  $A_s = 0.36 \text{ in}^2 / \text{ft}$ .

$$\text{Use } \phi 12 \text{mm, spacing} = \frac{0.20 * 12}{0.36} = 6.67" \equiv 6.5" \text{ c/c}$$

So, use  $\phi 12 \text{mm} @ 6.5" \text{ c/c}$ .

**B. Design of bottom slab:**

$$\frac{L}{B} = \frac{27}{11.5} = 2.35 \geq 2$$

So, it is a one- way slab.

Let the thickness of the slab is 20".

**Load calculation:**

$$\text{Water pressure} = 62.5 \times 6.5 = 406.25 \text{ psf}$$

$$\text{Self weight of the slab} = \frac{20}{12} \times 150 = 250 \text{ psf}$$

$$\text{Floor finish \& LL (assume)} = 20.0 \text{ psf}$$

---

$$\text{Total load, } W = 676.25 \text{ psf} = 0.676 \text{ ksf}$$

**Check for depth  $d$ :**

Moment in short direction

$$M = \frac{wL^2}{3} = \frac{0.676 \times 13.17^2}{3} = 39.08 \text{ k-ft}$$

$$L = 11.5 + \frac{20}{12} = 13.17 \text{ ft}$$

$$\therefore d = \sqrt{\frac{2 \times 39.08 \times 12}{1.35 \times 0.288 \times 0.904 \times 12}} = 14.91" < \text{provided } d = 20 - 1.5 = 18.5" \text{ ok.}$$

**Check against floatation:**

The whole tank must be checked against floatation when it is empty.

Because of saturated subsoil, there will be uplift pressure on the bottom slab.

- Total up-ward floatation force,  $P_u = \gamma h \times B \times L$   
 $= (62.5 \times 7) \times (11.5 + 1.67) \times (27 + 1.67) = 165.19 \text{ k}$
- Weight of 10" thick long and short walls  
 $= 0.83 \times (2 \times 13.17 + 2 \times 28.67) \times 7 \times 150 = 72.93 \text{ k}$
- Weight of 10" top slab  $= 0.83 \times 13.17 \times 28.67 \times 150 = 47.01 \text{ k}$
- Weight of 20" base slab  $= 1.67 \times 13.17 \times 28.67 \times 150 = 94.48 \text{ k}$
- Total downward weight  $= 214.52 \text{ k}$

This is greater than floatation force 214.52 k, so reservoir is safe in design.

**Reinforcement calculation:**

- **Main steel**

$$M = 39.08 \text{ kip-ft} = 468.96 \text{ kip-in (per ft run).}$$

$$A_s = \frac{M}{f_s j d} = \frac{468.96 \times 1000}{30000 \times 0.904 \times 18.5} = 0.93 \text{ in}^2/\text{ft}$$

$$\text{Minimum } A_s = 0.003bh = 0.003 \times 12 \times 10 = 0.36 \text{ in}^2/\text{ft}$$

$$\text{Selected } A_s = 0.93 \text{ in}^2/\text{ft.}$$

$$\text{Use } \phi 16\text{mm, spacing} = \frac{0.31 \times 12}{0.93} = 4" \text{ c/c}$$

So, use  $\phi 16\text{mm @ } 4" \text{ c/c.}$



- **Distribution Reinforcement**

$$\text{Minimum } A_s = 0.003bh = 0.003 \times 12 \times 10 = 0.36 \text{ in}^2 / \text{ft}$$

Selected  $A_s = 0.36 \text{ in}^2 / \text{ft}$ .

$$\text{Use } \phi 12\text{mm, spacing} = \frac{0.20 \times 12}{0.36} = 6.67" \approx 6.5" \text{ c/c}$$

So, use  $\phi 12\text{mm @ } 6.5" \text{ c/c}$ .

Reinforcement details of underground water reservoir are shown in Figures 4.21~4.22.

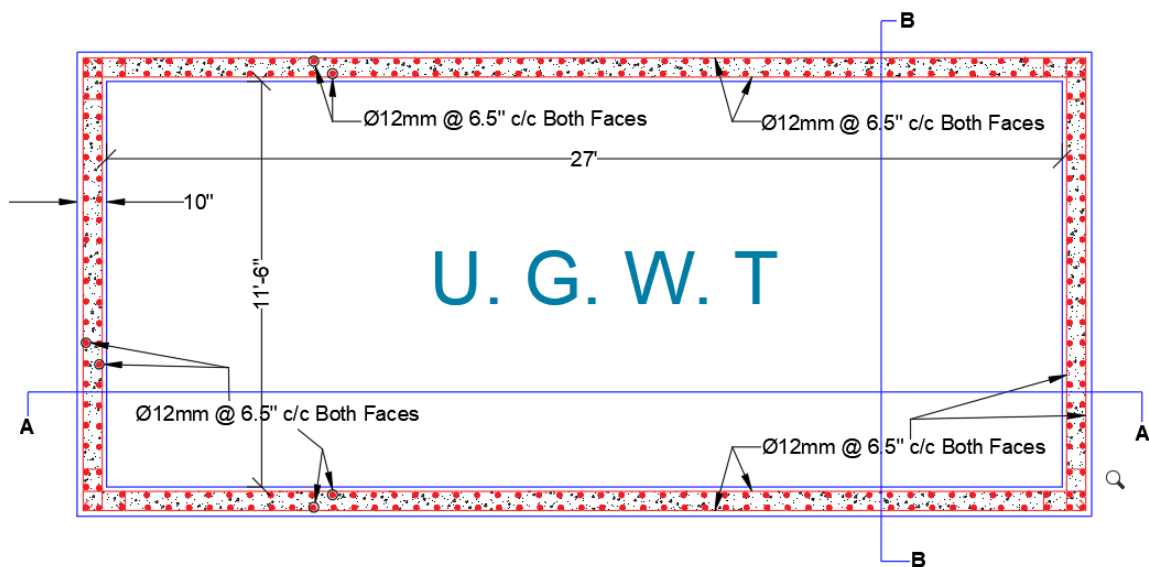

Figure 4.21a: Details of reinforcement arrangement of Wall of the underground water reservoir.

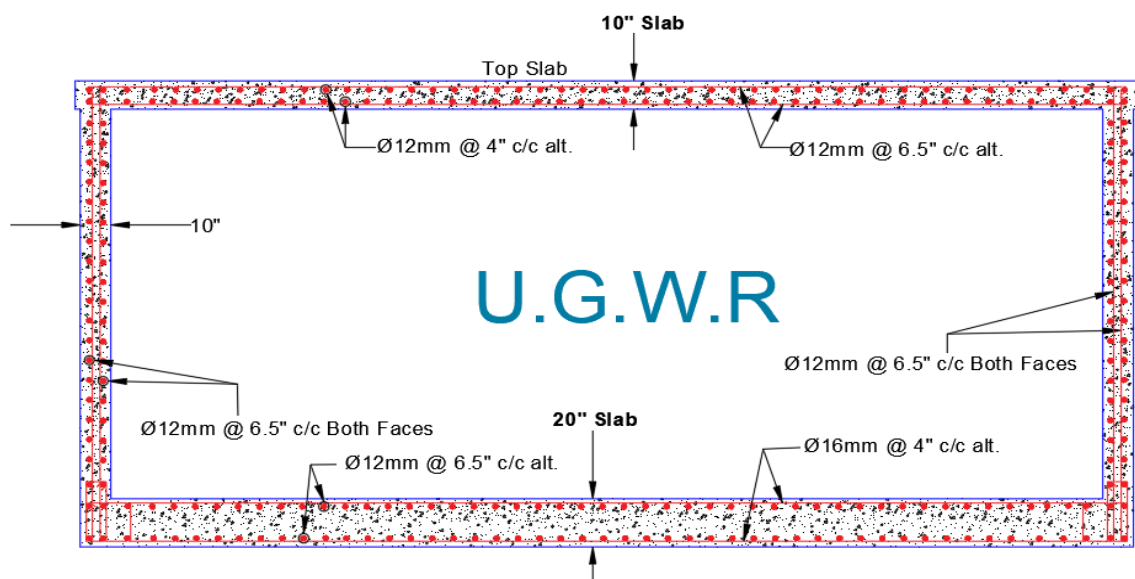

Figure 4.21b: Details of section A-A of the underground water reservoir.

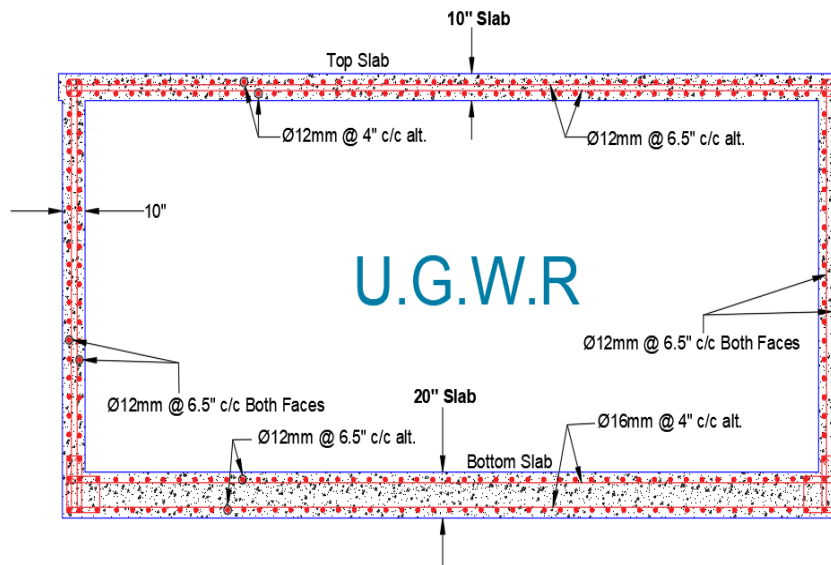

Figure 4.21c: Details of section B-B of the underground water reservoir.

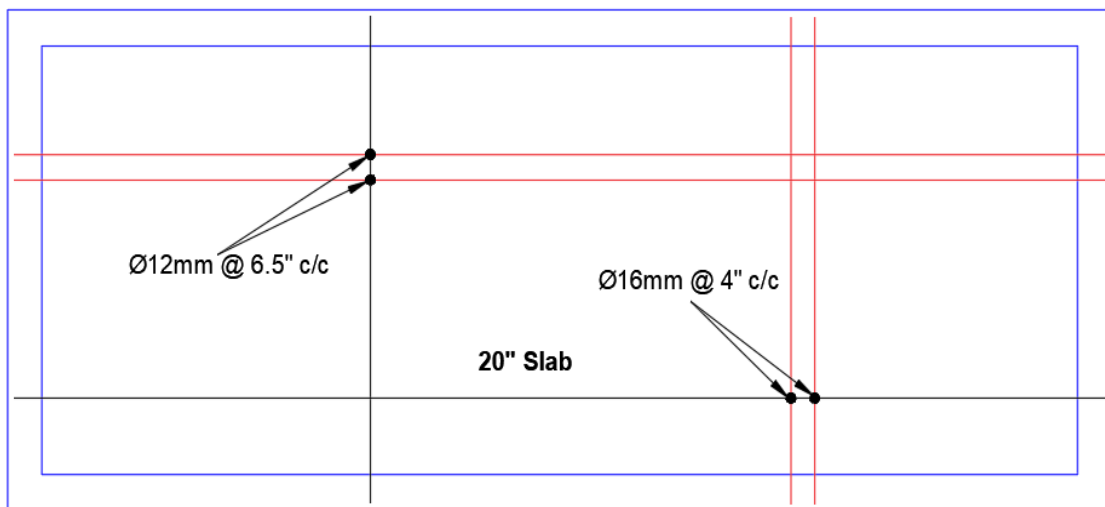

Figure 4.22a: Reinforcement details of bottom slab of the underground water reservoir.

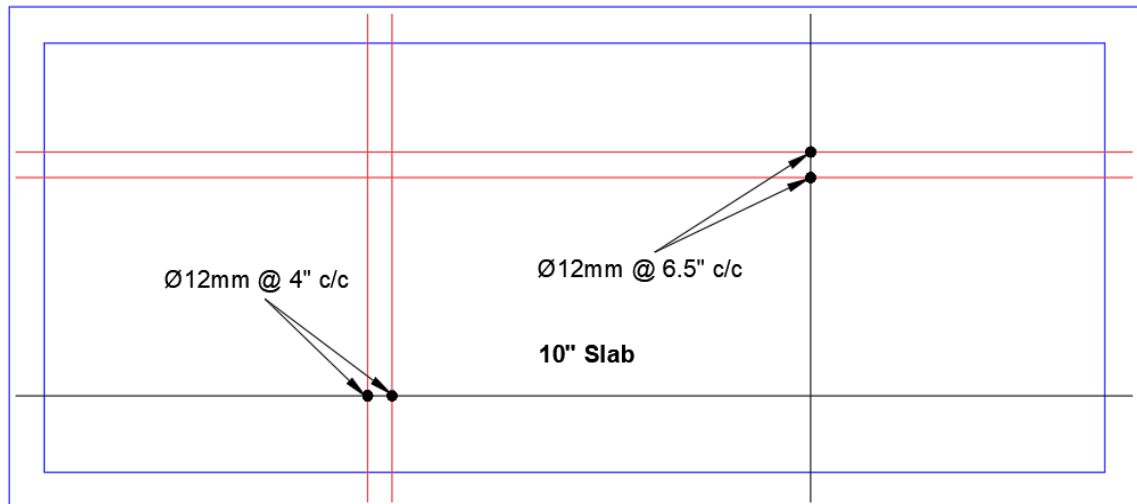

Figure 4.22b: Reinforcement details of top slab of the underground water reservoir.

## CHAPTER 5

# CONCLUSIONS & RECOMMENDATIONS

### 5.1 Conclusions

From the study, it is observed that:

- ❖ Preparation of Residential Floor plans for modern types building requires comparatively more efforts, attention and considerations according to the need of rentable spaces, owner desires, aesthetics, cost, safety and comfort of the visitors.
- ❖ Proper knowledge on software is essential for analysis of high-rise structure.
- ❖ Selection of loadings, materials & their properties should meet the requirement of building codes properly.

### 5.2 Recommendations

Based on the objectives, scopes and limitations of the study (stated in *Chapter 1*), few *recommendations* can be proposed for further studies:

- Column-beam joints are the important design consideration in a high-rise structure which were not done in this study is highly recommended in further studies.
- This study was conducted based on 18 storied Edge supported floor system, further analyses considering other floor system such as flat plate or flat slab can be considered to see the change in moment, shear, axial forces etc. in different building elements and also their cross-sectional dimensions as well reinforcement requirements.
- Sway and deflection control may be considered in analysis and design.

## REFERENCES

---

1. “*Reinforced Concrete Fundamentals*”, Ferguson P. M., Breen J. E. and Jirsa J. O.; 5<sup>th</sup> Edition, John Wiley & Sons, Inc., New York, 1987.
2. “*Tall Building Structures*”, Smith B.S. and Coull A.; John Wiley & Sons, Inc., New York, 1991.
3. “*Bangladesh National Building Code*”, 1<sup>st</sup> Edition, City Art Press, Dhaka, Bangladesh, 1993.
4. “*Seismic Design of Buildings and Bridges*”, Williams A.; Oxford University press, New York, 2003.
5. “*Reinforced Concrete Design*”, 3<sup>rd</sup> Edition, Everard N. J.; SCHAUM’S outlines, Tata McGraw-Hill Publishing Company Ltd, New Delhi, India, 2004.
6. “*American Concrete Institute Building Design Code*”, ACI, New York, USA, 2011.
7. “*Design of Concrete Structures*”, 14<sup>th</sup> Edition, Nilson A. H., Darwin D. and Dolan, C. W.; McGraw-Hill Publishing Company Ltd, New Delhi, India, 2014.